



DARTMOOR CATALOG **2013**

Dartmoor-Bikes. A group of friends with passion for gravity biking. Our brand comes from Poland but we are now almost all around the world. You may find among us team riders, new gear inventors, testers, technical designers, events' makers, gravity dedicated distributors and dealers. We create our custom designed dirt, street, freeride and downhill parts, frames and bikes. Before they reach the market they must go through the heavy duty testing process. In this catalog you can find what we prepared for you for the upcoming season and meet some of our team riders. We hope you will enjoy this as much as we did when we were working over this collection. So ... **RIDE YOUR WAY !!!**





Szymon is so young but already a living legend in Polish's gravity scene. A child prodigy that took Europe by storm and aims for the biggest jumps and contest in FMB World Tour circus! With his Dartmoor Cody bike the sky is the limit for this kid! When it comes to the more gnarly stuff he switches to his Shine or Wish bike, depending on the challenges he expects to meet. 26Trix, Crankworx, Claymore Challenge, Nine Knights contests as well as Woodward trips make up just part of his schedule. With his enormous talent and Red Bull/Dartmoor partnership don't even ask for his bag of tricks, you'll be there for days.

SZYMON GODZIEK

WISH PRO

Wish Pro bike is a build for all those bike lovers who look for some adrenaline in the mountains. You will have a great fun with this stunning machine in the bikeparks or on the big drops. Second edition of this top class compact freeride bike comes with some important upgrades like Rock Shox Lyrik Solo Air R, 160mm, tapered, with 20mm axle and Rock Shox Monarch air shock to let everyone adjust suspension to their needs and terrain requirements. With these changes the whole bike also became much lighter now.

Wish Pro is controlled via wide Dartmoor Nitro bars, top Avid Elixir 5 hydraulic brakes and Truvativ Hussefelt cranks with alu 7075 Dartmoor Totem chainring. Strong and lightweight wheels are based on the Raider rims with Revolt 20 front hub and Vee-Oh rear hub for increased stiffness. Drivetrain uses top SRAM components with X7 rear derailleur, X5 shifter and 9-speed cassette.

Top tube: 559mm; **Effective top tube:** 556mm; **Seat tube:** 343mm;
Rear triangle: 425mm; **BB height:** +12mm; **Head tube angle:** 66.5°;
Seat tube angle: 75°; **Dropouts:** 135x10mm; **Frame travel:** 160mm;
Shock size: 216x63mm; **Weight:** 15.5kg.

Frame: alu 7005 with 160mm travel and tapered head tube

Fork: Rock Shox Lyrik Solo Air R, 160mm, tapered, with 20mm axle

Shock: Rock Shox Monarch R 216x63mm

Handlebar: Dartmoor Nitro, alu 7075, diameter: 31.8mm, width: 780mm

Grips: Dartmoor Icon, length: 145mm, with alu lock rings and alu bar ends

Stem: Dartmoor Fury 2013 OEM, alu 6061, diameter: 31.8mm

Headset: Dartmoor Blaze OEM, sealed bearings

Crankset: Truvativ Hussefelt

Chainring: Dartmoor Totem 36T, alu 7075

BB: Truvativ How XR73 BB

Pedals: Dartmoor Stream Pro, sealed bearings

Chain guide: Dartmoor Blade ISCG-05

Chain: Shimano CN-HG53

Rear derailleur: SRAM X-7 9-speed

Shifter: SRAM X-5

Cassette: SRAM PG-950 11-28T

Rear hub: Dartmoor Vee-Oh OEM, 135x10mm, sealed bearings

Front hub: Dartmoor Revolt 20 OEM, sealed bearings

Spokes: steel with brass nipples, white

Rims: Dartmoor Raider 26", alu 6061, double wall, 36H

Tires: Kenda Nevegal 2.35"

Seat: Dartmoor Ivy

Seat post: Dartmoor Fusion L, alu 6061, diameter: 31.6mm, length: 300mm

Brake/lever (front/rear): Avid Elixir 5 with 203mm rotor





WISH

The Wish bike is created to offer this hi-end frame together with reliable components in more affordable package. Suspension is provided by the X-Fusion Vector shock working together with strong RST Storm Super tapered fork, offering you 160mm travel front and rear. Other components include: SRAM X-5 rear derailleur with X-4 shifter; Truvativ Ruktion cranks; aluminium Dartmoor Ice handlebar, new version of Fury stem and Raider rims with Vee-Oh/Dee-Force hubs.

Top tube: 559mm; **Effective top tube:** 556mm; **Seat tube:** 343mm; **Rear triangle:** 425mm; **BB height:** +12mm; **Head tube angle:** 66.5°; **Seat tube angle:** 75°. **Dropouts:** 135x10mm; **Frame travel:** 160mm; **Shock size:** 216x63mm; **Weight:** 17.5kg.

Frame: alu 7005 with 160mm travel and tapered head tube

Fork: RST Storm Super tapered, 160mm, with 20mm axle

Shock: X-Fusion Vector R 216x63mm

Handlebar: Dartmoor Fire, alu 6061, diameter: 31.8mm, width: 700mm

Grips: Dartmoor Icon, length: 145mm, with alu lock rings

Stem: Dartmoor Fury OEM, alu 6061, diameter: 31.8mm

Headset: Dartmoor Blaze OEM, sealed bearings

Crankset: Truvativ Ruktion, 36T chainring with Truvativ How XR73 BB

Pedals: Dartmoor Stream

Chain guide: Dartmoor Blade ISCG-05

Chain: KMC-X8

Rear derailleur: SRAM X-5

Shifter: SRAM X-4 8-speed

Cassette: SRAM PG-830 11-32T;

Rear hub: Dartmoor Vee-Oh, male Cr-Mo axle, sealed bearings

Front hub: Dartmoor Dee-Force, sealed bearings

Spokes: steel with brass nipples, black

Rims: Dartmoor Raider 26", alu 6061, double wall, 36H

Tires: Kenda Nevegal 2.35"

Seat: Dartmoor Ivy

Seat post: Dartmoor Fusion L, alu 6061, diameter: 31.6mm, length: 300mm

Brake/lever (front/rear): Promax DSK-907 hydraulic with 203mm rotor



HORNET

Multi purpose all mountain/freeride hardtail bike, which can be used for freeride trails, 4X tracks, local dirt trails and even easier downhill tracks. You can also use it for a relaxed off road afternoon ride with your friends. Hornet bike is equipped with such reliable parts and components like Truvativ cranks, Shimano 8-speed gears, Dartmoor wheelsets and cockpit, Kenda Kinetics tires, hydraulic brakes and RST Storm Super fork. For 2013 available only in 14" size.

Size: 14"; **Top tube:** 570mm; **Effective top tube:** 598mm; **Seat tube:** 356mm; **Rear triangle:** 420mm; **BB height:** +10mm; **Head tube angle:** 68°; **Seat tube angle:** 70°. **Weight:** 15.1kg.

Frame: Hornet OEM, alu 7005

Fork: RST Storm Super TA, 140mm, with 20mm axle

Handlebar: Dartmoor Fire, alu 6061, diameter: 31.8mm, width: 700mm

Grips: Dartmoor Icon, length: 145mm, with alu lock rings

Stem: Dartmoor Fury OEM, alu 6061, diameter: 31.8mm

Headset: 1.1/8" semi-integrated, sealed bearings

Crankset: Truvativ Ruktion, 36T chainring with Truvativ How XR68 BB

Pedals: Dartmoor Stream

Chain guide: Dartmoor Blade ISCG-03

Chain: Accent AC-881 Pro

Rear derailleur: Shimano Sora-2300 8-spd

Shifter: Shimano SL-M410 (Alivio)

Cassette: Shimano CS-HG50-8 12-25T;

Rear hub: Dartmoor X-Force, sealed bearings

Front hub: Dartmoor Dee-Force, sealed bearings

Spokes: steel with brass nipples, black

Rims: Dartmoor Raider 26", alu 6061, double wall, 32H

Tires: Kenda Kinetics 2.35"

Seat: Dartmoor Lite

Seat post: Dartmoor Fusion L, alu 6061, diameter: 31.6mm, length: 300mm

Brake/lever (front/rear): Promax DSK-907 hydraulic with 180mm rotor



SHINE

Following the success of our Shine frame we are introducing the second generation of this complete Slopestyle/Dirt Jump full suspension bike. Now the rear suspension is provided by the Rock Shox Monarch air shock and at the front you can find the new Suntour Duro Air fork which is becoming now very popular among the pro riders elite including Tomas Zejda. The braking power will provide now a set of Avid Elixir brakes.

Top tube: 554mm; **Seat tube:** 305mm; **Rear triangle:** 403mm; **BB height:** +3mm; **Head tube angle:** 69.5°; **Frame travel:** 100mm; **Shock size:** 190x50mm; **Weight:** 13.5kg.

Frame: alu 7005 with 100mm travel

Fork: Suntour SF12-DURO-DJ RC 20QLC AIR, 100mm travel, with 20mm axle

Shock: Rock Shox Monarch R 190x51mm

Handlebar: Dartmoor Ice, alu 6061, diameter: 25.4mm, width: 700mm

Grips: Dartmoor Icon, length: 145mm, with alu lock rings and alu bar ends

Stem: Dartmoor Fury 2013 OEM, alu 6061, diameter: 25.4mm

Headset: Dartmoor Flash OEM, sealed bearings

Cranks: Truvativ Ruktion, 32T chainring, bashguard

BB: Truvativ How XR73

Pedals: Dartmoor Stream Pro, sealed bearings

Chain: Dartmoor Core 3/32"

Rear hub: Dartmoor Revolt Singlespeed OEM, with 13T driver, sealed bearings

Front hub: Dartmoor Revolt 20 OEM, sealed bearings

Spokes: steel with brass nipples, black

Rims: Dartmoor Raider 26", alu 6061, double wall, 36H

Tires: Kenda SBE 2.1"

Seat: Dartmoor Ivy

Seat post: Dartmoor Fusion, alu 6061, diameter: 27.2mm, length: 200mm

Brake/lever (front/rear): Avid Elixir 1 with 160mm rotor



TWO6PLAYER PRO

Top class aluminium hardtail for Dirt Jump/Skatepark/Slopestyle. Two6Player Pro version is based on the latest edition of the aftermarket Two6Player frame with all its hi-end features like hydroformed downtube, tapered chainstay, custom designed dropouts and BB-CS yoke. Suspension is provided by the lightweight Suntour Duro Air fork successfully used in the same frameset by Tomas Zejda. The other top components include Avid Elixir hydraulic brake, Raider rims, new Fury stem and Stream Pro pedals.

Top tube: 571mm; **Rear triangle:** 385mm; **BB height:** -9mm; **Head tube angle:** 69.5°; **Seat tube angle:** 70°; **Weight:** 11,95kg.

Frame: alu 7005 with hydroformed down tube and tapered head tube

Fork: Suntour SF12-DURO-DJ RC 20QLC AIR, 100mm travel, with 20mm axle

Handlebar: Dartmoor Ice, alu 6061, diameter: 25.4mm, width: 700mm

Grips: Dartmoor Icon, length: 145mm, with alu lock rings and alu bar ends

Stem: Dartmoor Fury 2013 OEM, alu 6061, diameter: 25.4mm

Headset: Dartmoor Flash OEM, sealed bearings

Cranks: Samox tubular, Cr-Mo 4130, splines: 8, axle: 19mm

Pedals: Dartmoor Stream Pro, sealed bearings

BB: Euro 19mm, 4 sealed bearings

Sprocket: Dartmoor Zulu 7075, 25T, alu 7075

Chain: Dartmoor Core 1/8"

Rear hub: Dartmoor Revolt Singlespeed OEM, with 10T driver, sealed bearings

Front hub: Dartmoor Revolt 20 OEM, sealed bearings

Spokes: steel with brass nipples, white

Rims: Dartmoor Raider 26", alu 6061, double wall, 36H

Tires: Kenda SBE 1.95"

Seat combo: Dartmoor Lite Combo

Brake/lever: Avid Elixir 1 with 160mm rotor



dartmoor-bikes.com





TWO6PLAYER

Nicely looking, entry/mid level bike with 26" wheels, perfect for Dirt Jump and Skatepark. This set is for those who prefer to buy a reliable complete bike than build their own. The Player frame brings perfect geometry confirmed by the results of the best Dartmoor team riders. This frame may be also a solid base for possible future upgrades.

The main changes in 2013 Two6Player are: new Suntour Duro DJ D spring suspension fork and new singlespeed rear hub with 14T freewheel and sealed bearings.

Top tube: 571mm; **Rear triangle:** 385mm; **BB height:** -15mm; **Head tube angle:** 70°; **Seat tube angle:** 73°. **Weight:** 13,5 kg.

Frame: alu 7005 with new custom yoke and dropouts design

Fork: Suntour Duro DJ D, 100mm travel, with 3/8" axle

Handlebar: Dartmoor Ice, alu 6061, diameter: 25.4mm, width: 700mm

Grips: Dartmoor Shamann, length: 150mm

Stem: Dartmoor Fury 2013 OEM, alu 6061, diameter: 25.4mm

Headset: solid steel cups with strong ball bearings

Cranks: Dartmoor Chukka OEM, Cr-Mo 4130, splines: 8, axle: 19mm

Pedals: Dartmoor Stream

BB: Euro 19mm, 4 sealed bearings

Chain: Dartmoor Core 1/8"

Rear hub: male singlespeed with 14T freewheel, sealed bearings

Front hub: male, sealed bearings

Rims: Dartmoor Raider 26", alu 6061, double wall, 36H

Tires: Kenda K-Rad 2.3"

Seat combo: Dartmoor Lite Combo

Brake/lever: Promax DSK-320 mechanical disc brake with 160mm rotor

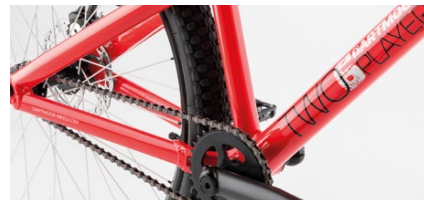
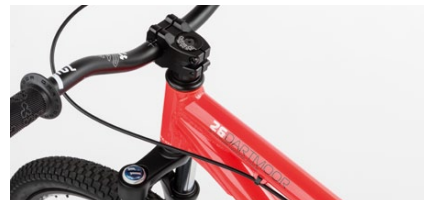

TWO4PLAYER

The Player complete bike with 24" wheels. Perfect for teenagers starting their Dirt Jump/Park adventure and all the 24" wheels enthusiasts. Set includes many high end components from the Dartmoor aftermarket collection or parts designed especially for the OEM bikes line plus reliable Suntour Duro DJ D suspension fork and Kenda K-Rad tires.

Top tube: 546mm; **Rear triangle:** 370mm; **BB height:** +3mm; **Head tube angle:** 70°; **Seat tube angle:** 75°. **Weight:** 13,2 kg.

Frame: alu 7005 with new custom yoke and dropouts design

Fork: Suntour Duro DJ D, 100mm travel, with 3/8" axle

Handlebar: Dartmoor Ice, alu 6061, diameter: 25.4mm, width: 700mm

Grips: Dartmoor Shamann, length: 150mm

Stem: Dartmoor Fury 2013 OEM, alu 6061, diameter: 25.4mm

Headset: solid steel cups with strong ball bearings

Cranks: Dartmoor Chukka OEM, Cr-Mo 4130, splines: 8, axle: 19mm

Pedals: Dartmoor Stream

BB: Euro 19mm, 4 sealed bearings

Chain: Dartmoor Core 1/8"

Rear hub: male singlespeed with 14T freewheel, sealed bearings

Front hub: male, sealed bearings

Rims: Dartmoor Raider 24", alu 6061, double wall, 36H

Tires: Kenda K-Rad 2.3"

Seat combo: Dartmoor Lite Combo

Brake/lever: Promax DSK-320 mechanical disc brake with 160mm rotor

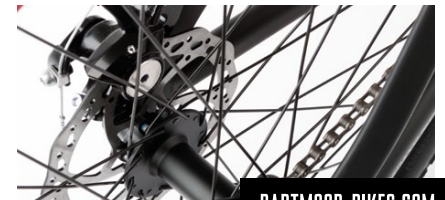



DARTMOOR-BIKES.COM



QUINNIE

Top class dirt jump / skatepark machine you can take out of the box and head directly for your dream contest. No weak parts included. Equipped with the new Suntour Duro Air fork and top class Dartmoor sealed bearings hubs. Pro geometry frame, fully made of 100% Cr-Mo 4130 steel with integrated seat clamp and head tube for integrated headset. Dartmoor aftermarket Raider rims, Shamann grips, Stream pedals, Zulu 7075 sprocket, Core chain and Lite seat combo. Dartmoor OEM Ice bars and Fury 2013 stem.

Top tube: 574mm; **Rear triangle:** 383mm; **BB height:** -10mm; **Head tube angle:** 70°; **Seat tube angle:** 72°. **Weight:** 12,2kg.

Frame: 100% Cr-Mo 4130 steel, integrated seat clamp

Fork: Suntour SF12-DURO-DJ RC 20QLC AIR, 100mm travel, with 20mm axle

Handlebar: Dartmoor Ice, alu 6061, diameter: 25.4mm, width: 700mm

Grips: Dartmoor Shamann, length: 150mm

Stem: Dartmoor Fury 2013 OEM, alu 6061, diameter: 25.4mm

Headset: Neco integrated Campy style 45/45, sealed bearings

Cranks: Samox tubular, Cr-Mo 4130, splines: 8, axle: 19mm

Pedals: Dartmoor Stream

BB: Spanish 19mm, press fit, sealed bearings

Sprocket: Dartmoor Zulu 7075, 25T, alu 7075

Chain: Dartmoor Core 1/8"

Rear hub: Dartmoor Revolt Singlespeed OEM, with 10T driver, sealed bearings

Front hub: Dartmoor Revolt 20 OEM, sealed bearings

Spokes: steel with brass nipples, black

Rims: Dartmoor Raider 26", alu 6061, double wall, 36H

Tires: Kenda SBE 1.95"

Seat combo: Dartmoor Lite Combo

Brake/lever: Avid Elixir 1 with 160mm rotor



DARTMOOR-BIKES.COM



QUANTUM

26" entry level hardtail, ready for skatepark and street riding. Full of hi-end Dartmoor components and ready for further upgrading. Custom designed frame with pro geometry with main tubes made of 100% Cr-Mo 4130 steel. With integrated seat clamp and head tube for integrated headsets. Dartmoor aftermarket Fortress rims, Shamann grips, Stream pedals, Core chain and Lite seat combo. Dartmoor OEM Ice bars, Fury 2013 stem, Chukka cranks and singlespeed rear hub with sealed bearings.

Top tube: 573mm; **Rear triangle:** 383mm; **BB height:** -10mm; **Head tube angle:** 70°; **Seat tube angle:** 72°. **Weight:** 13.2kg.

Frame: DT/TT/CS/SS/dropout made of Cr-Mo 4130, integrated seat clamp

Fork: steerer made of Cr-Mo 4130, 6mm thick dropouts, offset: 30mm

Handlebar: Dartmoor Ice, alu 6061, diameter: 25.4mm, width: 700mm

Grips: Dartmoor Shamann, length: 150mm

Stem: Dartmoor Fury 2013 OEM, alu 6061, diameter: 25.4mm

Headset: Neco integrated Campy style 45/45, sealed bearings

Crank: Dartmoor Chukka OEM, Cr-Mo 4130, splines: 8, axle: 19mm

Pedals: Dartmoor Stream

BB: Spanish 19mm, press fit, sealed bearings

Sprocket: 32T, Cr-Mo

Chain: Dartmoor Core 1/8"

Rear hub: male singlespeed with 14T freewheel, sealed bearings

Front hub: male, ball bearings

Spokes: steel with brass nipples, black

Rims: 26" alu 6061, double wall, 36H

Tires: Kenda K-Rad 2.3"

Seat combo: Dartmoor Lite Combo

Brake/lever: Alhonga V-Brake



The Czech's homeboy is one of the most remarkable riders from this beautiful country! He's a great guy for always smiling and playing around, until a competition comes around then it's a different matter. Tomas can be seen at the major jump comps such as Crankworx Whistler, Crankworx Les2Alpes, 26Trix, Claymore Challenge or Nine Knights riding either his Two6 Player or his Shine. With his bag of tricks containing jawdropping super-tailwhips, barspins to tailwhips and both way flip combos plus a butter smooth style - his is set to be a star of the future!

TOMAS ZEJDA





TESTED BY
★ Remek OLESZKIEWICZ ★

WISH

This frame is for all wishing to leave the city jungle or backyard dirt jumps to taste some real MTB freeriding. Wish is a lightweight suspension frame that will kick ass in the worlds best bikeparks, which are becoming so popular now. Compact geometry with aggressive angles makes the Wish really agile and reliable even at high speeds plus handles as well in the air as hitting up your local downhill trail. If you want to feel that you're fully in control of your bike - go for the Wish.

Frame is made of butted and heat treated 7005 aluminium with 160mm travel. Suspension has linear characteristic of the first stage of the stroke and becoming strongly progressive in the second stage. This makes the frame very sensitive to small bumps but also allows control for those the big hits and harsh landings. Tapered head tube works perfect with single crown forks with 160mm-180mm travel.

Available options: w/o shock; w/X-Fusion Vector R coil shock; w/X-Fusion O2 RCX AV air shock; w/Rock Shox Monarch High Volume air shock.

Frame travel: 160mm; **Shock size:** 216x63mm; **Bushing size:** 22.2x8mm;

Dropouts: 135x10mm; **BB:** Euro 73mm; **Headsets:** tapered (34mm/ 49,57mm);

Seat post diam.: 31.6mm; **Seat clamp diam.:** 34.9mm; **Size:** 14"; **Weight:** 2.98kg (w/o shock).

Rear triangle: 425mm; **Top tube:** 559mm; **Effect. top tube (160mm travel):** 556mm;

BB height (160mm travel): +12mm; **Head tube angle (160mm travel):** 66.5°.

Recommended fork travel: 160-180mm.



TESTED BY
★ Szymon GODZIEK ★

SHINE

One of the best full suspension slopestyle frames offering the riding comfort of suspension frame with modern geometry and stiffness of a dirt jump hardtail. Made of butted and heat treated 7005 aluminium. This frame takes the impact out of the biggest jumps, as well as offers a great ride to those wanting a play bike to hack in the woods. It has to be ridden to see just how cool and versatile this frame is. BB-centric pivot and horizontal dropouts lets you run the perfect single speed drive train without effecting the chain length. Simple and trouble-free suspension design with multipoint linking and big bearings on the BB make the construction as stiff as the typical DJ hardtail frame.

Shine has already proved that it's possible to build a very light slopestyle/dirt jump bike. You could see this frame in action at the biggest slopestyle events like Crankworx Whistler, Claymore Challenge or 26Trix.

Available options: w/o shock; w/X-Fusion Glyde RPV coil shock; w/X-Fusion O2 RCX air shock; w/Rock Shox Monarch R air shock.

Frame travel: 100mm; **Shock size:** 190x50mm; **Bushing size:** 22.2x8mm;

Dropouts: 135x10mm; **BB:** Euro 73mm; **Headsets:** tapered (34mm/49,57mm);

Seat post diam.: 27.2mm; **Seat clamp diam.:** 31.8mm; **Size:** 12"; **Weight:** 2.85kg (w/o shock).

Rear triangle: 403mm; **Top tube:** 554mm; **Reach (140mm travel):** 387mm; **Stack**

(140mm travel): 565mm; **BB height (140mm travel):** +16mm; **Head tube angle**

(140mm travel): 67.5°. **Recommended fork travel:** 100-140mm.



DARTMOOR-BIKES.COM



CODY

Dartmoor's most advanced Dirt Jump/Street steel frame for 26" wheels. Made of multiple butted, seamless Japanese Cr-Mo 4130 steel tubes. Heat treated before welding. With super smooth dropouts, hydroformed chainstay and increased thickness in the most sensitive areas this frame became now more reliable and desired than ever. Furthermore Cody is licensed to win any international contest by one of the world's top DJ riders Szymon Godziek. Hydroformed chainstay tubes increase stiffness, lower weight and give more clearance for the crankarms. Internal gusset under the head tube and perfectly smooth, small dropouts for a clean look. Integrated seat clamp in the top tube. Head tube for Campy style 45/45 integrated headsets. Gyro tabs holes in the head tube.

Dropouts: 135x10mm; **BB:** Spanish 68mm; **Headsets:** integrated 45°x45°; **Seat post diam.:** 27.2mm. **Seat clamp:** integrated; **Size:** 11.8". **Weight:** 2,26kg.

Rear triangle: 380mm; **Top tube:** 573mm; **Reach (100mm travel):** 402mm; **Stack (100mm travel):** 543mm; **BB height (100mm travel):** 0mm; **HT angle (100mm travel):** 68.5°. **Recommended fork travel:** 80-110mm or rigid fork.



ALEXEY SINAYKO

Alexey is the most recognizable Russian street rider with a huge influence on the MTB street riding scene all over the world. He can pull most of his tricks like tailwhips, truck drivers or clicked tabletops just from a bunny hop! Street drops, walls and stairs are his playground but we bet you will be amazed even when he rides flat ground on his Cody build. Beautiful style and crazy tricks will amaze you while watching his edits.

QUINNIE

The best middle range dirt jump/street frame for 26" wheels, perfect for all types of riders from amateur to pro. Made of butted, seamless Japanese Cr-Mo 4130 steel tubes. The Quinnie combines high quality level, modern design and perfect geometry. It has internal gusset under the head tube, seat clamp integrated in the seat tube and gyro tabs holes in the head tube.

Dropouts: 135x10mm; **BB:** Euro 68mm; **Headsets:** integrated 45°x45°; **Seat post diam.:** 27.2mm. **Seat clamp:** integrated; **Size:** 11.8". **Weight:** 2.4kg.

Rear triangle: 383mm; **Top tube:** 574mm; **Reach (100mm travel):** 402mm; **Stack (100mm travel):** 543mm; **BB height (100mm travel):** 0mm; **HT angle (100mm travel):** 68.5°. **Recommended fork travel:** 80-110mm.





MARIS ORNINS

Maris is the most talented rider in Latvia and all Baltic States where he rules both parks and dirt jumps. Maris built his own dirt jump spot in the local forest, which looks insane. Just check out his video edits or photos to see what we mean!



Piotr is shredding around with his Ghetto/Bronx combo to prove that 24" wheels are still in a game! Living in Leszno close to the biggest Polish outdoor skatepark he can ride every day and living the dream, while picking up the most creative lines.

PIOTR PRZYWECKI



TESTED BY
★ Piotr PRZYWECKI ★

GHETTO

Lightweight and very compact technical street frame for 24" wheels and rigid fork or short travel suspension fork. Ghetto is made of multiple butted, seamless Japanese Cr-Mo 4130 steel tubes. With v.3 series of this frame we decided to change its butting and heat treatment specification. Now tubing has an increased thickness in most sensitive areas and heat treatment is done for all the tubes before welding. As a result we have even stronger frame in more affordable price. Hydroformed chainstay tubes are increasing stiffness, lowering weight and giving more clearance for the crankarms. Internal gusset under the head tube and small dropouts for a clean look. Integrated seat clamp in the top tube. Head tube for Campy style 45/45 integrated headsets. Gyro tabs holes in the head tube.

Dropouts: 135x10mm; **BB:** Spanish 68mm; **Headsets:** integrated 45°x45°; **Seat post diam.:** 27.2mm. **Seat clamp:** integrated; **Size:** 10.6". **Weight:** 2.16kg.

Rear triangle: 360mm; **Top tube:** 546mm; **Reach (80mm travel):** 390mm; **Stack (80mm travel):** 507mm; **BB height (80mm travel):** +24mm; **HT angle (80mm travel):** 70°. **Recommended fork travel:** 60-100mm or rigid fork.

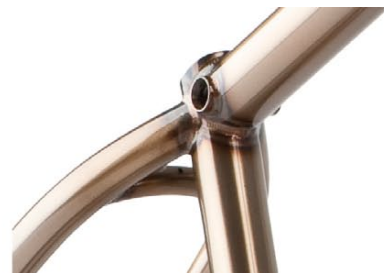

FREAKY

Heavy duty MTB street machine now made of butted Sanko Cr-Mo 4130 steel tubes. If you are a grinding lover or you like big gaps from the stairs - this frame is for you. Freaky has a compact geometry designed for 24" wheels but it will also take 26" wheels. Equipped with the integrated seat clamp. Ready to use with BMX rear hub, pegs, rigid fork and BMX cranks. If you want it with brakes it has removable U-brake pivots.

Dropouts: 110x14mm; **BB:** Spanish 68mm; **Headsets:** integrated 45°x45°; **Seat post diam.:** 25.4mm. **Seat clamp:** integrated; **Size:** 10". **Weight:** 2.44kg.

Rear triangle: 365mm; **Top tube:** 555mm; **Reach (rigid fork):** 418mm; **Stack (rigid fork):** 510mm; **BB height (rigid fork):** +5mm; **HT angle (rigid fork):** 72.5°. **Recommended fork travel:** 60-80mm or rigid fork.



BRONX V.2

Lightweight fork made of triple butted Cr-Mo 4130 steel. Post-weld heat-treated. Molded bottom section of the legs. Steerer tube and legs machined inside for weight reduction. 1-piece CNC machined steerer tube. With integrated crown race to fit 45/45 Campy style bearings. Top cap made of 7075-T6 aluminium.

Height: 430mm. **Steerer length:** 180mm. **Offset:** 25mm. **Weight:** 1.07kg.





TESTED BY
★ Tomas ZEJDA ★

TWO6PLAYER

Lightweight Dirt Jump/Park/Slopestyle frame made of butted and heat treated 7005 aluminium tubes. Introduction of our custom designed and optimally butted hydroformed down tube fitted to the new tapered head tube dramatically increased strength of this frame in 2012 season. As the result we had an impressive growth of sale and literally zero claims for 2012 edition of Two6Player frame after the first season.

But we do not stop at this point. The main changes for 2013 are: custom designed asymmetrical yoke to fit bigger chainrings and make this area even stiffer; improved dropouts design for perfect matching the chainstay line and the new BB shell with 73mm width and ISCG-05 mount.

Two6Player will be available now in two sizes: Long and Short. The main difference is in the top tube length. **Size Long** is pretty similar in geometry to the previous versions of this frame and will be perfect for Dirt and Slopestyle. **Size Short** with more compact geometry should be better for Skatepark and for the young, entry level riders.

Please note: Two6Player should only be used with suspension forks.

Dropouts: 135x10mm; **BB:** Euro 73mm; **Headsets:** tapered (34mm/49,57mm); **Seat post diam.:** 27.2mm. **Seat clamp diam.:** 31.8mm; **Weight:** 2.10kg. **Recommended fork travel:** 90-130mm.

Size Long: Rear triangle: 385mm; **Top tube:** 574mm; **Reach (130mm travel):** 397mm; **Stack (130mm travel):** 576mm; **BB height (130mm travel):** -8mm; **HT angle (130mm travel):** 67°.
Size Short: Rear triangle: 385mm; **Top tube:** 545mm; **Reach (130mm travel):** 367mm; **Stack (130mm travel):** 576mm; **BB height (130mm travel):** -8mm; **HT angle (130mm travel):** 67°.



TESTED BY
★ Maris ORNINS ★

TWO4PLAYER

Lightweight Dirt Jump/Skatepark frame for 24" wheels. Made of butted and heat treated 7005 aluminium tubes. Two4Player 2013 will be equipped with the new custom designed asymmetrical yoke and improved dropouts design for perfect matching the chainstay line. Double butted top tube with increased thickness in the head tube area. Head tube takes standard 1.1/8" headsets, machined internally for weight reduction.

Please note: Two4Player should only be used with suspension forks.

Dropouts: 135x10mm; **BB:** Euro 68mm; **Headsets:** a-head 1.1/8"; **Seat post diam.:** 27.2mm. **Seat clamp diam.:** 31.8mm; **Size:** 11.8". **Weight:** 1.98kg.

Rear triangle: 370mm; **Top tube:** 546mm; **Reach (100mm travel):** 394mm; **Stack (100mm travel):** 539mm; **BB height (100mm travel):** +3mm; **HT angle (100mm travel):** 69°. **Recommended fork travel:** 70-100mm (for 24" wheels).



Antti is the first man in the gravity biking history to make the crazy cash-roll trick on the MTB bike! That's what you call fame! Big and risky tricks like cash-rolls or double backflips are something what really turns him on when he rides his red Two6Player. That was so much harder for him as he was growing up in Finland where you can hardly find any big jumps. Now we all wait for him to join the FMB World Tour in 2013 to prove his skills!

ANTTI RISSANEN



TESTED BY
★ Jakub HNIDAK ★

PHANTOM

Ultra light 4X/Dual Slalom/Freeride frame made of butted and heat treated 7005 aluminium tubes. Light and stiff with perfect geometry, very fast out of the gate and easy to control in the corners. Now it comes with a new asymmetric BB-CS yoke what gives even more chainring and tyre clearance. New Phantom will be equipped also with the new BB shell with 73mm width and ISCG-05 mount. New seat tube for 31.6mm seat post will make the whole frame even more stiff than before. Phantom comes with a hydroformed down tube and tapered head tube what gives a much stronger connection than a standard welded gusset and looks much cleaner. Head tube takes the Blaze or Flash headsets and all forks with 1.1/8" or tapered steerer. Replaceable gear hanger.

Dropouts: 135x10mm; **BB:** Euro 73mm; **Headsets:** tapered (34mm/49,57mm); **Seat post diam.:** 31.6mm. **Seat clamp diam.:** 34.9mm; **Size:** 13.5". **Weight:** 2.05kg.

Rear triangle: 400mm; **Top tube:** 580mm; **Effect. top tube (100mm travel):** 609mm; **BB height (100mm travel):** -13mm; **HT angle (100mm travel):** 67°. **Recommended fork travel:** 80-130mm.



Jakub is one of the fastest Czech 4X riders and also one of the best in the world! In the new 4X Pro Tour 2012 series he finished 11th in the overall ranking with 5th and 6th places reached respectively in Szczawno and Val di Sole rounds. Dartmoor proudly supports his speed with the Phantom frame, Raider rims and other components!

HORNET

Universal and multi purpose lightweight All Mountain/Freeride/4X hardtail frame made of butted and heat treated 7005 aluminium tubes. Hornet 2013 will be equipped with the new BB shell with 73mm width and ISCG-05 mount. This frame is still available in three sizes and comes with a hydroformed down tube and tapered head tube what gives a much stronger connection than a standard welded gusset and looks much cleaner. Head tube takes the Blaze or Flash headsets and all forks with 1.1/8" or tapered steerer. New profiled curved seat stay gusset. Replaceable gear hanger.

Dropouts: 135x10mm; **BB:** Euro 73mm; **Headsets:** tapered (34mm/49,57mm); **Seat post diam.:** 31.6mm; **Seat clamp diam.:** 34.9mm; **Sizes:** 14", 16", 18". **Weight:** 2.20kg (14"), 2.24kg (16"), 2.30kg (18").

Rear triangle: 420mm.
Top tube: 570mm (14"), 575mm (16"), 604mm (18").
Effect. top tube (150mm travel): 601mm (14"), 608mm (16"), 643mm (18").
BB height (150mm travel): -8mm.
HT angle (150mm travel): 67.5°. **Recommended fork travel:** 100-150mm.



JAKUB HNIDAK



THORN

2-pcs design cranks made of heat-treated Cr-Mo 4130 steel with 22mm spindle and 48 splines. RHD/LHD compatible. Two sprocket holes to fit all sprocket sizes. Small gusset to make the pedals assembly area stronger. Includes arms, spindle (welded to the right arm), 2 spindle bolts (alu 7075-T6 and Cr-Mo), 2 sprocket bolts (bigger one is hollow) and assembly/disassembly tool.

Now available with 2 spindle lengths: 160mm (**Thorn MTB**) designed to work with Euro external bearings (like Dartmoor Euro eX BB 22mm) with 68mm or 73mm BB shells to create an extra strong and efficient combination with frames like Two6Player
150mm (**Thorn BMX**) perfectly working with Spanish or MID BB equipped frames as well as standard Euro BB to minimize number of required spacers for such kind of frames and keep correct chain line

Arms length: 170 mm. **Spindle:** 22mm hollow. **Splines:** 48. **Spindle bolt:** 5/8"x24T (8mm Allen key). **Weight:** 745g (with alu spindle bolt), 763g (with Cr-Mo spindle bolt).



CHUKKA TWO

3-pcs design reliable, entry level cranks made of 100% Cr-Mo 4130 steel seamless tubes. Includes arms, spindle, Cr-Mo spindle bolts, sprocket bolt and pinch bolts.

Arms length: 175 mm. **Spindle:** 19mm. **Splines:** 8. **Weight:** 1100g.



KEIPO

3-pcs design cranks made of heat-treated 100% Cr-Mo 4130 steel. RHD/LHD compatible. Two sprocket holes to fit all sprocket sizes. Small gusset to make the pedals assembly area stronger. Includes arms, spindle, Cr-Mo spindle bolts, 2 sprocket bolts (bigger one is hollow) and pinch bolts. Alu spindle bolts available as separate spare parts.

Arms length: 175 mm. **Spindle:** 19mm hollow. **Splines:** 16. **Spindle bolts:** M12x1mm (6mm Allen key). **Pinch bolts:** M6x1mm. **Weight:** 835g.

KEIPO EX

Light and strong 3-pcs cranks with external Euro BB bearings included for 68mm and 73mm BB shells. Crank arms made of heat-treated 100% Cr-Mo 4130 steel. Two sprocket holes to fit all sprocket sizes. Small gusset to make the pedals assembly area stronger. Axle length is adjusted to fit external bearings

Arms length: 175mm. **Spindle:** 19mm hollow. **Spindle length:** 148mm. **Splines:** 16. **Weight:** 995g (including Euro eX BBs).

FLARE

Light and strong 2.5-pcs cranks made of heat-treated Cr-Mo 4130 steel with 19mm spindle and 48 splines. RHD/LHD compatible. Two sprocket holes to fit all sprocket sizes. Small gusset to make the pedals assembly area stronger. Includes arms, spindle (pressed into the right arm), Cr-Mo spindle bolt, 2 sprocket bolts (bigger one is hollow), assembly tool.

Arms length: 170 mm. **Spindle:** 19mm hollow. **Splines:** 48. **Spindle bolt:** M12x1mm (6mm Allen key). **Weight:** 814g.





FEVER V.2

Ultra light pedals made of cold forged and CNC machined aluminium. Custom body shape with slim, flat profile. Cr-mo steel axle. 2 sealed bearings and DU-bushing for perfect and smooth rotation. For 2013 they come with the extended axle to increase the Q-factor and riding comfort. Tightened with 15mm wrench or 8mm Allen key. Fevers come with 8 removable, black pins per side.

Height: 16mm. **Platform size:** 90x100mm. **Weight:** 395g.



STREAM PRO

Lightweight alu die casted pedals with perfect grip and strong body design. Cr-mo steel axle. Sealed bearing and DU-bushing. 10 pins per side (6 removable). 2 new color options.

Height: 18mm. **Platform size:** 90x95mm. **Weight:** 440g.



STREAM

Lightweight alu die casted pedals with perfect grip and strong body design. Cr-mo steel axle. Ball bearings. 10 pins per side (6 removable). 2 new color options.

Height: 18mm. **Platform size:** 90x95mm. **Weight:** 440g.

EURO EX BB



External bearings with Euro alu bottom bracket cups. Much bigger and stronger bearings than in standard Euro BB cups. Two inner sleeves for 68mm and 73mm bottom bracket shells and a set of alu spacers included. For 19mm or 22mm axle.

Weight: 160g.

Attention: these BB sets are dedicated only for cranks with extended spindle length (like Thorn MTB or Keipo eX).

SPANISH BB



Spanish standard bottom bracket bearings. Two inner sleeves for 68mm and 73mm bottom bracket shells and a set of alu spacers included. Option for 19mm or 22mm axle.

Weight: 138g (19mm), 107g (22mm).

EURO BB



Euro standard bottom bracket bearings with alu cups. Two sealed bearings in each cup. Two inner sleeves for 68mm and 73mm bottom bracket shells and a set of alu spacers included. Option for 19mm or 22mm axle.

Weight: 152g (19mm), 118g (22mm).

MID BB



Mid standard bottom bracket bearings. Two inner sleeves for 68mm and 73mm bottom bracket shells and a set of spacers included. Option for 19mm or 22mm axle.

Weight: 185g (19mm), 169g (22mm).

COOKIE

Lightweight pedals made of nylon. Cr-mo steel axle. Ball bearings. Knurled surface and 12 molded pins per side for maximum traction. New, blue color option.

Height: 23mm. **Platform size:** 90x95mm. **Weight:** 315g.





REMEK OLESZKIEWICZ

Remek is a true 4X and Freeride machine. He is a long term Dartmoor Team member who has been with us from the very beginning. He has tested every generation of our race frames and brought most of them to the podium! Nowadays he can be seen ripping through the trails on his Wish Pro set up and smashes 4X courses on his Phantom frame, with a Hornet as his funbike when he is teaching young kids how to improve their racing skills in beautiful Polish forests!





TOTEM

Lightweight MTB chainring made of high quality 7075-T6 aluminium. Fully CNC machined according to our custom design. Up to 30%-40% lighter than 6061 aluminium chainrings.
Size: 32T, 34T, 36T, 38T. **BCD:** 104mm. **Thickness:** 4mm. **Teeth:** 3/32". **Weight:** 40g (32T), 50g (34T), 63g (36T), 79g (38T).



DISCO

Fully CNC machined small MTB chainring made of 7075-T6 aluminium. For those who use driver hubs (9T-11T) but prefer to keep lightweight MTB cranks.
Size: 25T. **BCD:** 64mm. **Thickness:** 5mm. **Teeth:** 1/8". **Weight:** 45g.

TRANCE

Fully CNC machined sprocket made of 7075-T6 aluminium with 8 spokes design. Adapters for 19mm and 22mm axle included.
Size: 23T, 25T, 28T. **Thickness:** 6mm. **Teeth:** 3/32". **Weight:** 56g (23T), 65g (25T), 90g (28T).

FETISH

Fully CNC machined sprocket made of 7075-T6 aluminium with 5 spokes design. Adapters for 19mm and 22mm axle included.
Size: 23T, 25T. **Thickness:** 6mm. **Teeth:** 3/32". **Weight:** 58g (23T), 66g (25T).



SIMPLE

Single lower arm chain guide with CNC holes pattern in backplate for weight reduction. Backplate made of aluminium. Roller with sealed bearing. Together with bashguard may be used for double chainring drive.

Thickness: 3mm. **Weight:** 85g (ISCG-03), 95g (ISCG-05).

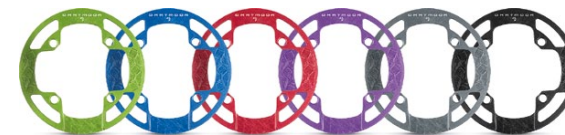

CONQUEST

Ultralight bashguard made of 4mm thick aluminium alloy. With cuts in the body for weight reduction.
Thickness: 4mm. **Size:** 36T-38T. **Weight:** 75g.



BLADE

Lightweight chain guide with CNC holes pattern in backplate for weight reduction. Adjustable full cage on upper arm. Backplate made of aluminium. Available in ISCG-03 or ISCG-05 option. BB adapter included.

Size: 32T-42T. **Thickness:** 4mm. **Weight:** 156g (ISCG-03), 160g (ISCG-05).

CORE LIGHT

Lightweight nickel-plated chain with hollow pins and drilled side plates. Masterlink included. Nano-coated color options.

Length: 102 links. **Width:** 1/8". **Weight:** 226g (for 72 links).



CORE

Strong chain with drilled top side plates. Masterlink included. Painted color options.

Length: 102 links. **Width:** 1/8". **Weight:** 276g (for 72 links).



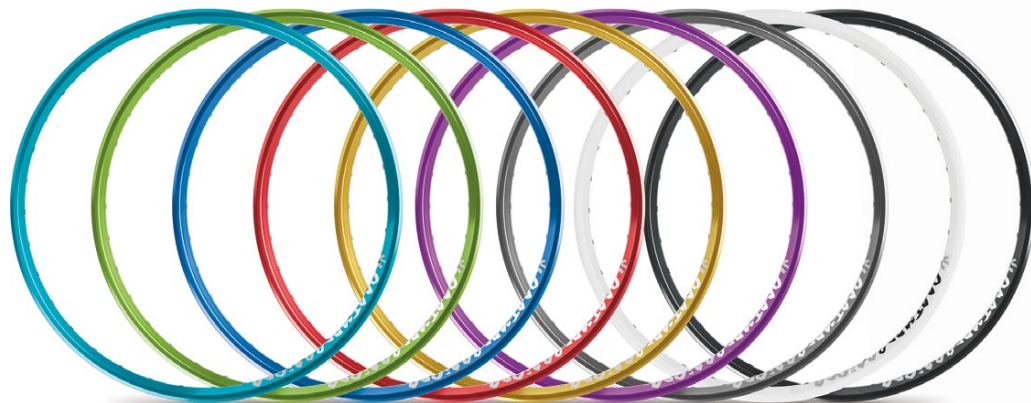

RAIDER

Very popular lightweight rim for Dirt Jump, Street, 4X, Enduro, Freeride and Downhill. Made of 6061 aluminium. Double wall with eyelets. Disc brake only.

Outer width: 31.4mm. **Inner width:** 24mm. **Height:** 21mm. **ERD:** 533.6mm (26"), 481.6mm (24"), 380.6mm (20").
Size: 26", 24", 20". **Holes:** 36, 32. **Weight:** 550g (26"), 500g (24"), 405g (20").

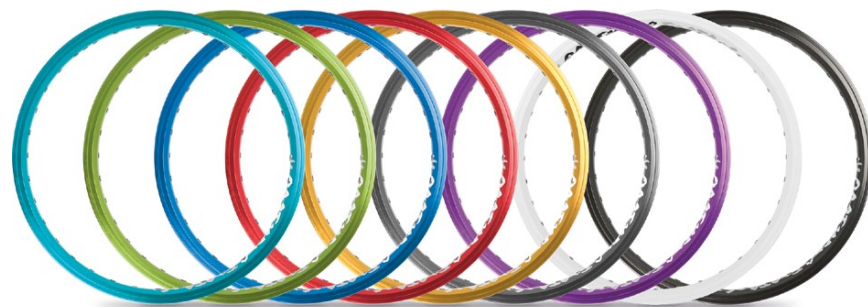

FORTRESS

Popular strong rim for BMX, Dirt Jump and Street. Made of 6061 aluminium. Double wall with eyelets. Side wall for V-Brake and U-Brake.

Outer width: 32.4mm. **Inner width:** 25mm. **Height:** 21mm. **ERD:** 533.5mm (26"), 481.5mm (24"), 380.5mm (20").
Size: 26", 24", 20". **Holes:** 36, 32. **Weight:** 670g (26"), 595g (24"), 485g (20").



REVOLT

New hi-end gravity rim in Dartmoor range made of custom designed profile to fit the most demanding requirements for Downhill, Freeride, Enduro, Dirt Jump and Street riding. Made of the top quality 6066-T6 aluminium with the sleeve joint connection.

Strictly and successfully tested by most of our top riders including Szymon Godziek (DJ), Piotr Krajewski (DJ), Michał Śliwa (DH), Arek Perin (DH, Enduro), Remek Oleszkiewicz (FR) and Piotr Przywecki (Street/Skatepark).

Outer width: 33.5mm. **Inner width:** 27mm. **Height:** 22mm. **ERD:** 531.6mm (26"), 479.6mm (24"). **Size:** 26", 24". **Holes:** 36, 32.
Weight: 525g (26"), 465g (24").

RIM TAPE

Long lasting rim tape made of impregnated nylon with Ride Your Way printed logo. Available in 26" and 24" size.

Width: 26mm. **Size:** 26", 24".





Q-Lai (Q-Lite) drive system with 6 double independent pawls located in the hub body. This perfect engagement system will avoid any skipping plus have a longer life as well as delivering really loud clicks.



REVOLT PRO CASSETTE

New and totally hi-end rear cassette hubs family in Dartmoor range. We bring the same Q-Lai drive transmission technology which was successfully launched in single speed Revolt Pro hub in 2012 into a whole family of MTB rear cassette hubs. 6 big pawls located in the body plus 5 top quality sealed bearings, alu 7075 cassette body and push-in cones, hard anodized alu 7075 axle and perfect sealing secured by a set of o-rings and lip seals make these hubs a perfect weapon of choice for all Downhill, Freeride, All Mountain, Enduro and XC riders.

And last but not the least – they are pretty lightweight and available in all necessary size options: **150x12mm**

135/142x12mm (a set of included extra cones makes possible to easily convert it from 135mm to 142mm size)

135x10mm in female version with 3/8" Cr-Mo hollow bolts.

All size options are available also in red anodized finish.

SPECIFICATION:

Hub-shell: alu 6061-T6

Axle: hard anodized alu 7075-T6

Bolts: hollow Cr-Mo 3/8"x24T, heat-treated for 17mm wrench or 8mm Allen key (only in 135x10mm female option)

Cones: alu 7075-T6, push-in (both sides)

Bearings: 5 precision sealed bearings (x3 in driver, x2 in hub shell)

Cassette: alu 7075-T6 (necessary to use freewheel with alu spider), 9/10 speed

Pawls: 6 pawls design with 6 individual, double springs

Engagement points: 30

Holes: 36H/32H

Weight: 292g (150x12mm), 289g (135/142x12mm), 369g (135x10mm)



REVOLT PRO SINGLESPEED

Absolutely hi-end ultralight MTB single speed rear hub. 9T driver with patented Q-Lai drive transmission technology with 6 double independent pawls located in the hub body. This makes more space inside the driver for 3 bearings. Together with 2 bearings in the body this makes our Revolt Pro a really smooth rolling and strong hub. 9T driver works perfectly with 23T sprockets.

15mm 7075 aluminium inner axle has a female system with hollow Cr-Mo 3/8" bolts (for 17mm wrench or 8mm Allen key). Hub body made of 6061 aluminium. The push-in cones made of 7075 aluminium.

Size: 135x10mm. **Holes:** 36, 32. **Driver:** 9T. **Pawls:** 6. **Engagement points:** 30. **Weight:** 380g.



REVOLT SINGLESPEED

Lightweight MTB single speed rear hub with 10T driver and 6 pawls working in a 2-stage system. Revolt is equipped with 3 bearings inside the driver and 2 in the body.

15mm 7075 aluminium inner axle has a female system with hollow Cr-Mo 3/8" bolts (for 17mm wrench or 8mm Allen key). Hub body made of 6061 aluminium. The push-in cones made of 7075 aluminium.

Size: 135x10mm. **Holes:** 36, 32. **Driver:** 10T. **Pawls:** 6. **Engagement points:** 48. **Weight:** 405g.





One of the fastest Polish DH racers, well known on European tracks for more than a decade! After hitting up the Masters category in 2012 where he reached the second place in European Ch-ships now he comes back to fight with the best riders in Elite category. His experience and great testing feedback helped us to improve our FR/DH collection including the Wish frame, new Revolt Pro Cassette hubs, Revolt rims, Nitro bars and Rage stem. Michal's desire for speed is still in his mind and he loves having fun whether it is MX, rally cars or winter sports.

MICHAŁ SŁIWA



If you want to find more about this guy just check the top 5 spots in all this year's biggest Polish DH and Enduro contests! Times tumble when this guy hits the track with his skills. Confidence and loads of experience are on his side when the countdown begins. After dominating the Polish scene he is now on the way to claim his position in Europe. We are really proud to support him with our Revolt Pro Cassette hubs, Revolt rims, Nitro bars and Rage stem!

AREK PERIN



VEE-ONE

Very light cassette rear disc hub for 4X, enduro, XC. Hub body made of 6061 aluminium. 10mm hollow 7075 aluminium axle with 6mm female bolts. Cassette body made of 7075 aluminium. 4 high quality sealed bearings. Vee-One hub cannot be used in more heavy duty applications like freeride or dirt jump.
Size: 135x10mm. **Holes:** 36, 32. **Pawls:** 3. **Engagement points:** 24. **Weight:** 325g.



VEE-TWO

Very light front disc hub. Hub body made of 6061 aluminium. 9mm hollow 7075 aluminium axle with 6mm female bolts. 2 high quality sealed bearings. Machined cut-outs in disc side flange and disc brake mount for weight reduction.
Size: 100x10mm. **Holes:** 36, 32. **Weight:** 203g.



QUANTIC

Lightweight downhill cassette rear disc hub. Hub body made of 6061 aluminium. Inner axle, cassette body and push-in cones made of 7075 aluminium. 4 high quality sealed bearings. Machined body, disc side flange and brake mount for weight reduction.
Size: 150x12mm. **Holes:** 36, 32. **Pawls:** 3. **Engagement points:** 24. **Weight:** 290g.



LITE-FORCE

Lightweight front disc hub for 20mm through axle. Hub body made of 6061 aluminium. 2 high quality sealed bearings. Machined disc side flange and brake mount for weight reduction.
Size: 110x20mm. **Holes:** 36, 32. **Weight:** 170g.



X-15

Ultralight front disc hub for 15mm through axle. Hub body made of 6061 aluminium. Axle made of 7075 aluminium. 2 high quality sealed bearings.
Size: 100x15 mm. **Holes:** 36, 32. **Weight:** 163g.



B-15

Ultralight front hub for 15mm through axle. Without disc brake mount. Hub body made of 6061 aluminium. Axle made of 7075 aluminium. 2 high quality sealed bearings.
Size: 100x15mm. **Holes:** 36, 32. **Weight:** 142g.



X-DRIVE

Lightweight front hub for 20mm through axle. Without disc brake mount. Custom body shape. Hub body made of 6061 aluminium. Axle made of 7075 aluminium. Two high quality sealed bearings.
Size: 110x20mm. **Holes:** 36, 32. **Weight:** 160g.

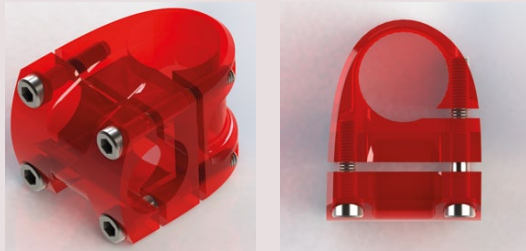

Dartmoor Micron is a minimalistic dirt jump and street stem. Ultra light and short but very stiff and durable thanks to a wide bar and steerer clamping area. Using 4 bolts instead of 6 allowed us to lower weight as well as shape it in a way that will not hurt your knees during an accidental kick. The two right bolts clamping the bar are also responsible for clamping the steerer tube but loosening them will not loosen the bars when you want to straighten the stem.



MICRON

Totally new Dartmoor MTB stem with integrated frontplate/steerer clamp design. Made of cold forged and CNC machined hi-end 6066-T6 aluminium with extensive internal machining and extremely short extension to make this small piece of art one of the lightest and most beautiful MTB stems ever.

Please note: when assembling the Micron stem it is very important that the steerer tube of the fork ends above the upper clamping bolt. The 4 bolts design of this stem may cause that after tightening it on the steerer tube it may be not perfectly straight. In such case just lose the longer bolts, adjust the position of the stem a little more counterclockwise and tighten again.

Bar bore: 25.4mm. **Extension:** 30mm. **Bolts:** M6x22mm (x2); M6x42mm (x2). **Weight:** 137g.



FURY

Classic heavy duty MTB gravity stem made of fully CNC machined 6061 aluminium.

Bar bore: 25.4mm, 31.8mm. **Extension:** 35mm (25.4mm), 40mm (31.8mm).

Weight: 165g (25.4mm), 185g (31.8mm).



RAGE

Lightweight downhill stem made of cold forged and CNC machined 7075 aluminium. Direct Mount standard for Boxxer and Fox forks.

Bar bore: 31.8mm. **Extension:** 45mm. **Weight:** 145g (with front plate bolts).



FUNKY

Our hi-end and unique stem made of cold forged and CNC machined 6061 aluminium. One of the lightest gravity stems on the market. Custom body shape with 2-pcs front plate design. All bolts are M6 size.

Bar bore: 25.4mm, 31.8mm. **Extension:** 35mm (25.4mm), 40mm (31.8mm). **Angle:** 0°. **Weight:** 148g (25.4mm), 170g (31.8mm).



RAGE V.2

Upgraded version of our hi-end downhill stem with adjustable extension and re-designed body. Direct Mount standard for Boxxer, Fox or Dorado forks. Made of cold forged and CNC machined 7075 aluminium. For 2013 we add to this stem a special washers securing the stem against changing its position when hitting the ground strongly. Available also in red and orange anodized finish.

Bar bore: 31.8mm. **Extension:** 45/50mm. **Weight:** 142g (with front plate bolts).



NITRO DH

Lightweight and super strong downhill handlebar made of butted 7075 aluminium. Super wide and comfortable with perfect shape. Strictly tested to meet our high custom requirements with increased load*.

Diameter: 31.8mm. **Width:** 780mm. **Rise:** 0.5". **Upsweep:** 5°. **Backsweep:** 9°. **Weight:** 320g.



NITRO 2012

Nitro bars in 2012 edition with classic Dartmoor logo and full range of colors (black, turquoise, green, red, blue, violet, gold, graphite, silver and white).

Diameter: 31.8mm. **Width:** 780mm. **Rise:** 0.5". **Upsweep:** 5°. **Backsweep:** 9°. **Weight:** 320g.



BOOGIE 2012

Boogie bars in 2012 edition with classic Dartmoor logo.

Diameter: 31.8mm. **Width:** 750mm. **Rise:** 2". **Upsweep:** 6°. **Backsweep:** 7°. **Weight:** 352g.



BOOGIE

Lightweight handlebar with oversized center section made of butted 7075 aluminium. Very wide and perfectly shaped with smooth bends. Strictly tested to meet our high custom requirements with increased load*.

Diameter: 31.8mm. **Width:** 750mm. **Rise:** 2". **Upsweep:** 6°. **Backsweep:** 7°. **Weight:** 352g.

NITRO FR

New option of popular Nitro bars with increased rise to fit requirements coming from many freeride and downhill riders. Made of butted 7075 aluminium. Still very light and super strong. Strictly tested to meet our high custom requirements with increased load*.

Diameter: 31.8mm. **Width:** 780mm. **Rise:** 1.5". **Upsweep:** 4°. **Backsweep:** 9°. **Weight:** 345g.



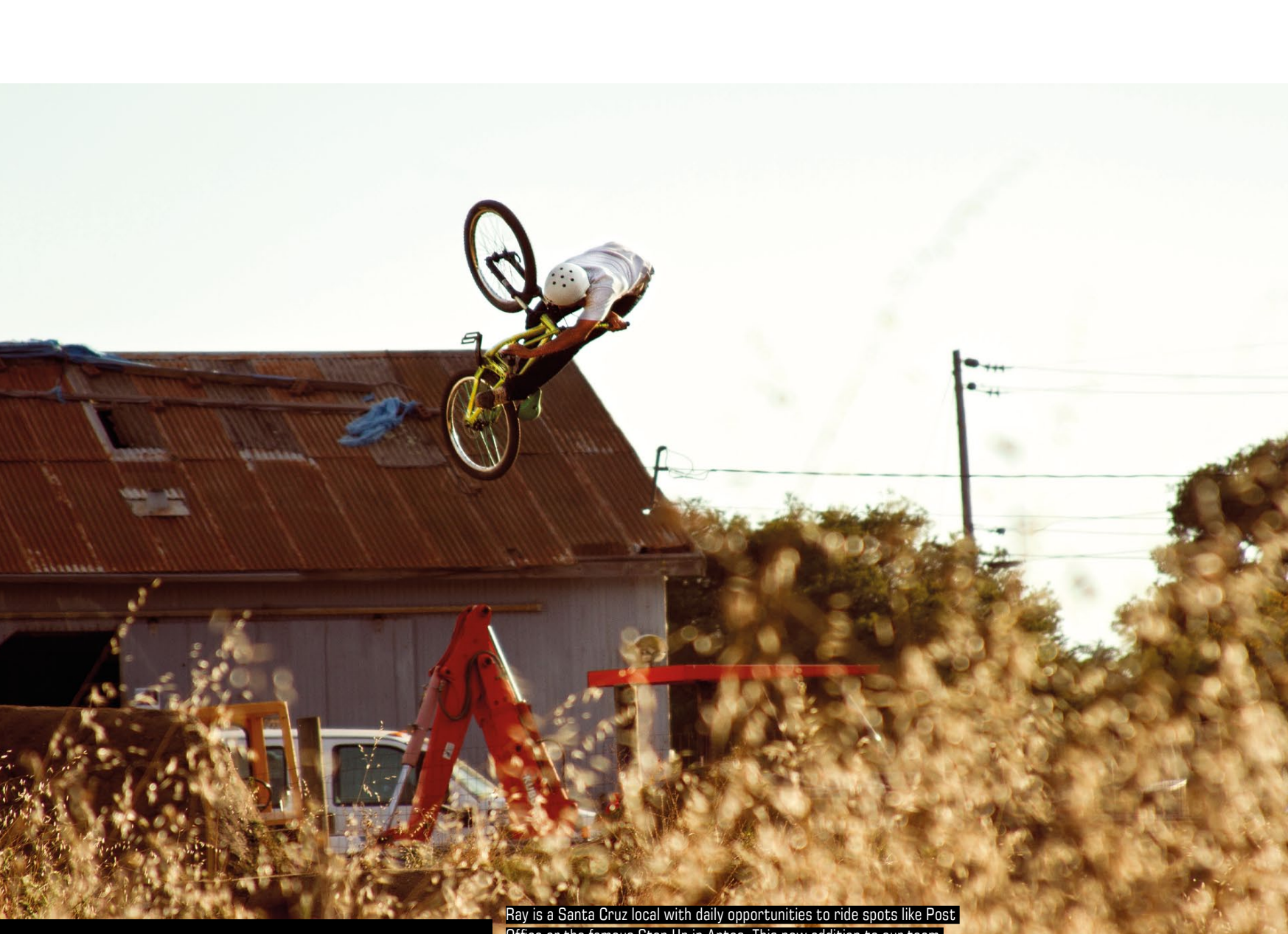

RAY GEORGE

Ray is a Santa Cruz local with daily opportunities to ride spots like Post Office or the famous Step Up in Aptos. This new addition to our team is known to ride big jumps with overflowing style. Clicked tables, 360's combinations or just crazy whips over huge gaps are normal routine with his green Shine, sunny yellow Two6Player or grey Wish. We hope for California's sun to push him in to go even bigger in the future.



NICK CLARKE

Brought up in the small town of Mount Albert in Canada, 19 years old Nick Clarke has become widely known for his unique riding style and superb bike control. As a famous Joyride 150 skatepark local, Nick continues to push his personal boundaries and show the world what he has to offer. Technical bar spins and front flips combos are among his favorite tricks he is serving us with his awesome Two6Player.



TOXIC

Strong street handlebar made of butted and fully heat treated Cr-Mo 4130 steel. High rise and comfortable geometry. Strictly tested to meet our high custom requirements with increased load*.

Diameter: 22.2mm. **Width:** 720mm. **Rise:** 3.5". **Upsweep:** 5°. **Backsweep:** 8°. **Weight:** 455g.



TOXIC 2012

Toxic bars in 2012 edition with classic Dartmoor logo.

Diameter: 22.2mm. **Width:** 720mm. **Rise:** 3.5". **Upsweep:** 5°. **Backsweep:** 8°. **Weight:** 455g.



SWING LOW 2012

Swing Low bars in 2012 edition with classic Dartmoor logo and full range of colors (black, turquoise, green, red, blue, violet, gold, graphite, silver and white).

Diameter: 25.4mm. **Width:** 750mm. **Rise:** 2". **Upsweep:** 6°. **Backsweep:** 7°. **Weight:** 365g.



SWING HI

Lightweight handlebar made of butted 7075 aluminium. High rise and perfect shape with smooth bends. Strictly tested to meet our high custom requirements with increased load*.

Diameter: 25.4mm. **Width:** 710mm. **Rise:** 3.5". **Upsweep:** 6°. **Backsweep:** 7°. **Weight:** 365g.

SWING LOW

Lightweight handlebar made of butted 7075 aluminium. Very wide and perfectly shaped with smooth bends. Strictly tested to meet our high custom requirements with increased load*.

Diameter: 25.4mm. **Width:** 750mm. **Rise:** 2". **Upsweep:** 6°. **Backsweep:** 7°. **Weight:** 365g.

SWING HI 2012

Swing Hi bars in 2012 edition with classic Dartmoor logo and full range of colors (black, turquoise, green, red, blue, violet, gold, graphite, silver and white).

Diameter: 25.4mm. **Width:** 710mm. **Rise:** 3.5". **Upsweep:** 6°. **Backsweep:** 7°. **Weight:** 365g.

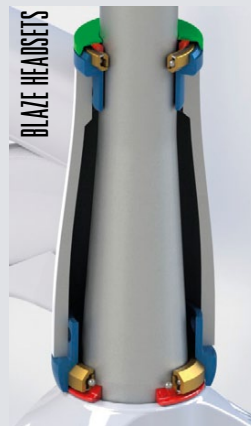

TAPERED HEAD TUBE / HEADSETS

The tapered head tube standard gained much popularity in the last 3 years on the gravity oriented MTB market. It has many useful advantages like increased stiffness and durability in frames, headsets and forks. Unfortunately the simultaneous development of the tapered head tube by the several bike brands resulted in 4 different standards. At the same time every standard also needs the possibility to fit a classic fork with 1.1/8" steerer tube.

Dartmoor helps here and offers all the major standards used in the gravity bikes. Our headsets can be used in 9 different frame/fork configurations. Each of them is using top quality sealed bearings covered with anti-rust titanium coating and custom shaped hi-end 2014 aluminium cups.

FLASH

Top quality headsets for tapered head tubes and forks with standard 1.1/8" steerer tubes. Cups and top cover made of 2014 aluminium. Threadless upper cup drilled for weight reduction with ultra low profile top cover. Semi-integrated lower cup with 1.1/8" reduction integrated in the cup's body. High quality precision sealed 45/45 bearings with anti-rust titanium coating. Custom compression cap included. Designed to fit Shine, Wish, Two6Player, Phantom and Hornet frames.

Head tube type: tapered. Fork type: 1.1/8" steerer tube. **Assembly dimensions:** 34/49,57mm. **Stack height:** 12.7+2.8=15.5mm. **Weight:** 109g (w/o top cap).



BLAZE

Top quality headsets for tapered head tubes and forks with tapered or standard 1.1/8" steerer tubes. Cups and top cover made of 2014 aluminium. Both threadless cups drilled for weight reduction. High quality precision sealed 45/45 bearings with anti-rust titanium coating. Custom compression cap included. Now they come with two steel crown races – for tapered or 1.1/8" forks. Designed to fit Shine, Wish, Two6Player, Phantom and Hornet frames.

Head tube type: tapered. Fork type: tapered or 1.1/8" steerer tube. **Assembly dimensions:** 34/49,57mm. **Stack height:** 12.7+13.2=25.9mm. **Weight:** 126g (w/o top cap).



CHARGE

Top quality threadless 1.1/8" headsets with drilled alu cups and high quality precision sealed 45/45 bearings with anti-rust titanium coating. Deep cups for better alu head tubes protection. Custom compression cap included.

Stack height: 12.7+13.1=25.8mm. **Weight:** 99g (w/o top cap).

PRIME

45/45 Campy style 1.1/8" integrated headsets with ultra low profile alu top cover. High quality precision sealed bearings with anti-rust titanium coating. Custom compression cap included.

Stack height: 4.9+0.8=5.7mm. **Weight:** 61g (w/o top cap).



ASTRO

Headsets for tapered head tubes and forks with tapered or standard 1.1/8" steerer tubes. Semi-integrated aluminium cups. High quality precision sealed 45/45 bearings with anti-rust titanium coating. Coming with two steel crown races – for tapered or 1.1/8" forks.

Stack height: 9.0+2.8=11.8mm. **Weight:** 120g (w/o top cap). **Assembly dimensions:** 44/55.95mm.



DIVE

Semi-integrated headsets for 1.5" head tubes and forks with standard 1.1/8" steerer tubes. Reductions integrated in the cups' bodies. High quality precision sealed 45/45 bearings with anti-rust titanium coating.

Stack height: 7.4+2.8=10.2mm. **Weight:** 142g (w/o top cap). **Assembly dimensions:** 44/49,57mm.

SPIN

Headsets for tapered head tubes and forks with tapered or standard 1.1/8" steerer tubes. Semi-integrated upper cup and threadless lower cup drilled for weight reduction. High quality precision sealed 45/45 bearings with anti-rust titanium coating. Coming with two steel crown races – for tapered or 1.1/8" forks.

Stack height: 9.0+13.2=22.2mm. **Weight:** 122g (w/o top cap). **Assembly dimensions:** 44/49,57mm.

EXILE

Headsets for tapered head tubes and forks with standard 1.1/8" steerer tubes. Semi-integrated aluminium cups. Lower cup with 1.1/8" reduction integrated in the cup's body. High quality precision sealed 45/45 bearings with anti-rust titanium coating.

Stack height: 9.0+2.8=11.8mm. **Weight:** 106g (w/o top cap). **Assembly dimensions:** 44/49,57mm.



FATTY COMBO

Extra thick foam padded seat with 1-pc covering, nylon base and alu 6061-T6 post. Embossed Dartmoor logo. Now it comes in 4 different color options matching Cookie pedals and Shamann/Icon grips colors.

Seat size: 230x143mm. **Seat post size:** 25,4x160mm, 27,2x200mm. **Weight:** 356g.



FATTY

Extra thick foam padded Pivotal seat with 1-pc covering and nylon base. Hollow Pivotal bolt for decreased weight. Embossed Dartmoor logo. Now it comes in 4 different color options matching Cookie pedals and Shamann/Icon grips colors.

Seat size: 234x142mm. **Weight:** 329g.



LITE

Slim padded Pivotal seat with 1-pc covering and nylon base. Hollow Pivotal bolt for decreased weight. Embossed Dartmoor logo.

Seat size: 230x129mm. **Weight:** 264g.



LITE COMBO

Slim padded seat with 1-pc covering, nylon base and alu 6061-T6 post. Embossed Dartmoor logo. Now it comes in 4 different color options matching Cookie pedals and Shamann/Icon grips colors.

Seat size: 222x125mm. **Seat post size:** 27,2x200mm. **Weight:** 265g.

STICKY COMBO

Extra slim padded seat with 1-pc covering, nylon base and alu 6061-T6 post. With embossed Dartmoor logo.

Seat size: 222x120mm. **Seat post size:** 25,4x160mm. **Weight:** 249g.



BAMBOO

Ultra light plastic seat with nylon base and alu 6061-T6 post.

Seat size: 217x113mm. **Seat post size:** 25,4x160mm. **Weight:** 189g.



IVY

Thick foam padded Pivotal seat with 1-pc covering and nylon base. Hollow Pivotal bolt for decreased weight. Embossed Dartmoor logo. Now it comes in 4 different color options matching Cookie pedals and Shamann/Icon grips colors.

Seat size: 232x134mm. **Weight:** 292g.



FUSION

Pivotal seat post. Made of 6061 aluminium. Available also in long version (L).
Diameter: 25.4mm, 27.2mm, 30.9mm, 31.6mm.
Length: 130mm (25.4mm), 200mm (27.2mm), 400mm (27.2mm, 30.9mm, 31.6mm).
Weight: 116g (25.4mm), 140g (27.2/200mm), 240g (27.2/400mm), 300g (30.9mm), 310g (31.6mm).

SHAMANN

High flanges grips made of special rubber compound with increased durability and extra softness for very comfortable using. Plastic bar plugs included (screw type).
Length: 150mm. **Diameter:** 30mm.
Weight: 154g (plugs included).



DARTMOOR-BIKES.COM



RING

Lightweight seat clamp made of CNC machined aluminium. Bolt with 4mm Allen key socket.
Diameter: 31.8mm, 34.9mm. **Weight:** 18g (31.8mm), 20g (34.9mm).



EVOLUTION

Classic BMX grips with high flange and mushroom pattern. Made of Kraton.
Length: 147mm. **Weight:** 151g (plugs included).

ICON

Lightweight and comfortable MTB grips with lock-on alu clamps and Ride Your Way alu bar ends. 145mm length gives you plenty of room for barspins and other tricks. Custom design with Dartmoor logo in the grip pattern. Special compound material – very comfortable and with increased durability. Alu bar ends for better handlebar protection.
Length: 150mm. **Diameter:** 32mm.
Weight: 138g (clamps/bar ends included).



RACE

Classic MTB grips with lock-on alu clamps and mushroom pattern. Made of Kraton.
Length: 135mm, 145mm. **Weight:** 122g (145mm with clamps/plugs included).



PIOTR KRAJEWSKI



Warsaw's crazy boy known for his dialed supermen and backflip combinations. Whether he's using his Quinnie or Shine bikes he can tailwhip off any obstacle you point him at. This locally respected and globally known surfer boy is one of the craziest guys in our crew. You could see this in both our Ride Your Way productions. He loves to hit up a road-trip and have fun with everybody he meets on his way!



Laszlo 'Cusi' Gal is the best street/park rider in Hungary and he forged his position as a park shredder by winning the 2012 Bike Hall Contest in Trutnov. He is mostly into very technical tricks like flips to fakies on the quarter pipes, truck drivers to foot jams or double bars on gaps – just the limits of his imagination can stop him on his Cody build.

LASZLO GAL



SPOKES

Strong, cold forged spokes made of highest quality Swedish Sandvik T302 stainless steel. Quality comparable to the other best spokes on the market. 36 spokes in a package.

Finish: oxidized (black); metallic (gold, violet, blue, green, red); painted (light blue, orange, yellow, white).

Lengths (mm): 264, 262, 260, 258, 256, 254, 252, 250, 236, 234, 232, 230, 228, 226, 188, 186, 184, 182, 180.

Weight: 244g (258mm / metallic finish).



NIPPLES

Aluminium nipples. 3 times lighter than standard brass nipples. Beautiful anodized colors. 38 nipples in a package.

Length: 12mm. **Weight:** 11g (set).

Warning: It is strictly recommended to use assembling tool dedicated for alu nipples and determine correct length of spokes when building up the wheel. Using standard tool (for brass nipples) or too short spokes may cause breaking of the alu nipples.

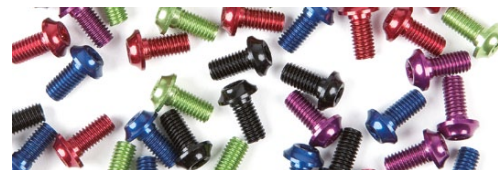

ALU ROTOR BOLTS

Aluminium rotor bolts for T20 Torcx tool. Special alloy and increased head strength to avoid breaking. Beautiful anodized colors. 6 bolts in a package.

Weight: 6g (set).



NANO

One of the lightest disc rotors. Made of stainless steel. High abrasion and temperature resistance. Special design provides fast heat dissipation.

Sizes: 140mm, 160mm. **Weight:** 68g (140mm), 86g (160mm).



SNAKE

Long finger gloves. Made of rip-proof fabrics. Well ventilated. Anti-slip silicone dot pattern on the inside of the palm.

Sizes: S-XXL.

RIDE YOUR WAY

Cotton t-shirts with Dartmoor and Ride Your Way logos. Three different styles.

PRESSURE

Shin protectors with anatomically fitted design. Made of strong neoprene with hard but flexible inserts for better protection. Good ventilation and sweat absorption.

Now available also in the small size to fit the youngest riders.

Sizes: S, M, L.



ESSENCE

Shin protectors with anatomically fitted design. Made of strong neoprene with hard but flexible inserts for better protection. Good ventilation and sweat absorption.

Sizes: M, L.





Ryan Nangle - the rider, the trail builder and the movie maker. The UK has one of the best and biggest gravity biking scenes and you really need to stand-out to be noticed there. Ryan does this in bucket loads. He is a real pleasure to watch when flowing over the jumps on his Shine or Two6Player. Each of his productions is pure eye candy and gets thousands of hits on Pinkbike. He's a regular on the podiums in the UK dirt jump series by throwing down flip combos and one of the best 360's variations. Getting noticed is not an issue

RYAN NANGLE



Marcel Hunt - the other side of the UK duo. A regular in Ryan Nangles edits with his own style and stunning tattoos! He is a super nice and chilly dude from Andover, UK, who knows there is no riding without digging. Next to the shovel Marcel uses his Cody frame to throw down his tricks in any way he desires. Dirt jumps and trails are his best playgrounds where he spends most of his time.

MARCEL HUNT

HUB	RIM	RIM SIZE	HOLES	INTER-SECTIONS	RECOMMENDED SPOKES LENGTH
Revolt Pro Cassette 150x12mm	Revolt	26"	36	3	252/254
Revolt Pro Cassette 150x12mm	Revolt	26"	32	3	256/258
Revolt Pro Cassette 150x12mm	Fortress/Raider	26"	36	3	254/256
Revolt Pro Cassette 150x12mm	Fortress/Raider	26"	32	3	258/260
Revolt Pro Cassette 135x10mm; 135/142x12mm	Revolt	26"	36	3	252
Revolt Pro Cassette 135x10mm; 135/142x12mm	Revolt	26"	32	3	256
Revolt Pro Cassette 135x10mm; 135/142x12mm	Revolt	24"	36	3	226
Revolt Pro Cassette 135x10mm; 135/142x12mm	Revolt	24"	32	3	230
Revolt Pro Cassette 135x10mm; 135/142x12mm	Fortress/Raider	26"	36	3	254
Revolt Pro Cassette 135x10mm; 135/142x12mm	Fortress/Raider	26"	32	3	258
Revolt Pro Cassette 135x10mm; 135/142x12mm	Fortress/Raider	24"	36	3	228
Revolt Pro Cassette 135x10mm; 135/142x12mm	Fortress/Raider	24"	32	3	232
Revolt Pro Singlespeed	Revolt	26"	36	3	252
Revolt Pro Singlespeed	Revolt	26"	32	3	256
Revolt Pro Singlespeed	Revolt	24"	36	3	226
Revolt Pro Singlespeed	Revolt	24"	32	3	230
Revolt Pro Singlespeed	Fortress/Raider	26"	36	3	254
Revolt Pro Singlespeed	Fortress/Raider	26"	32	3	258
Revolt Pro Singlespeed	Fortress/Raider	24"	36	3	228
Revolt Pro Singlespeed	Fortress/Raider	24"	32	3	232
Revolt Singlespeed	Revolt	26"	36	3	252
Revolt Singlespeed	Revolt	26"	32	3	256
Revolt Singlespeed	Revolt	24"	36	3	226
Revolt Singlespeed	Revolt	24"	32	3	230
Revolt Singlespeed	Fortress/Raider	26"	36	3	254
Revolt Singlespeed	Fortress/Raider	26"	32	3	258
Revolt Singlespeed	Fortress/Raider	24"	36	3	228
Revolt Singlespeed	Fortress/Raider	24"	32	3	232
K-Drive	Revolt	26"	36	3	254
K-Drive	Revolt	26"	32	3	258
K-Drive	Revolt	24"	36	3	228
K-Drive	Revolt	24"	32	3	230
K-Drive	Fortress/Raider	26"	36	3	256
K-Drive	Fortress/Raider	26"	32	3	260
K-Drive	Fortress/Raider	24"	36	3	230
K-Drive	Fortress/Raider	24"	32	3	232
Quantic	Revolt	26"	36	3	256
Quantic	Revolt	26"	32	3	254
Quantic	Fortress/Raider	26"	36	3	256/258
Quantic	Fortress/Raider	26"	32	3	258/260
Vee-One	Revolt	26"	36	3	256
Vee-One	Revolt	26"	32	3	254
Vee-One	Fortress/Raider	26"	36	3	258/256
Vee-One	Fortress/Raider	26"	32	3	260/258
Vee-Oh	Revolt	26"	36	3	256
Vee-Oh	Revolt	26"	32	3	254
Vee-Oh	Fortress/Raider	26"	36	3	258/256
Vee-Oh	Fortress/Raider	26"	32	3	260/258
X-Drive	Revolt	26"	36	3	254
X-Drive	Revolt	26"	32	3	258
X-Drive	Revolt	24"	36	3	230
X-Drive	Revolt	24"	32	3	232
X-Drive	Fortress/Raider	26"	36	3	256
X-Drive	Fortress/Raider	26"	32	3	260
X-Drive	Fortress/Raider	24"	36	3	232
X-Drive	Fortress/Raider	24"	32	3	234
Lite-Force	Revolt	26"	36	3	252/256
Lite-Force	Revolt	26"	32	3	254/258
Lite-Force	Fortress/Raider	26"	36	3	254/258
Lite-Force	Fortress/Raider	26"	32	3	256/260
Dee-Force	Revolt	26"	36	3	252
Dee-Force	Revolt	26"	32	3	256
Dee-Force	Fortress/Raider	26"	36	3	254
Dee-Force	Fortress/Raider	26"	32	3	258
B-15	Revolt	26"	36	3	256

HUB	RIM	RIM SIZE	HOLES	INTER-SECTIONS	RECOMMENDED SPOKES LENGTH
B-15	Revolt	26"	32	3	258
B-15	Revolt	24"	36	3	230
B-15	Revolt	24"	32	3	232
B-15	Fortress/Raider	26"	36	3	258
B-15	Fortress/Raider	26"	32	3	260
B-15	Fortress/Raider	24"	36	3	232
B-15	Fortress/Raider	24"	32	3	234
X-15	Revolt	26"	36	3	252/256
X-15	Revolt	26"	32	3	254/258
X-15	Fortress/Raider	26"	36	3	254/258
X-15	Fortress/Raider	26"	32	3	256/260
Vee-Two	Revolt	26"	36	3	254/256
Vee-Two	Revolt	26"	32	3	256/258
Vee-Two	Fortress/Raider	26"	36	3	256/258
Vee-Two	Fortress/Raider	26"	32	3	258/260
Razor/Razor v.2	Revolt	26"	36	3	252/254
Razor/Razor v.2	Revolt	24"	36	3	226/228
Razor/Razor v.2	Fortress/Raider	26"	36	3	254/256
Razor/Razor v.2	Fortress/Raider	24"	36	3	228/230
Razor/Razor v.2	Fortress/Raider	20"	36	3	182/180
Sector/Sector RHD/Sector LHD	Revolt	26"	36	3	252/254
Sector/Sector RHD/Sector LHD	Revolt	24"	36	3	226/228
Sector/Sector RHD/Sector LHD	Fortress/Raider	26"	36	3	254/256
Sector/Sector RHD/Sector LHD	Fortress/Raider	24"	36	3	228/230
Sector/Sector RHD/Sector LHD	Fortress/Raider	20"	36	3	182/180
B-One	Revolt	26"	36	3	254
B-One	Revolt	24"	36	3	230
B-One	Fortress/Raider	26"	36	3	256
B-One	Fortress/Raider	24"	36	3	232
B-One	Fortress/Raider	20"	36	3	184
Razor Park	Revolt	26"	36	3	258
Razor Park	Revolt	26"	32	3	260
Razor Park	Revolt	24"	36	3	234
Razor Park	Revolt	24"	32	3	236
Razor Park	Fortress/Raider	26"	36	3	260
Razor Park	Fortress/Raider	26"	32	3	262
Razor Park	Fortress/Raider	24"	36	3	234
Razor Park	Fortress/Raider	24"	32	3	236
Razor Park	Fortress/Raider	20"	36	3	186
Razor Park	Fortress/Raider	20"	32	3	188
Razor Street	Revolt	26"	36	3	258
Razor Street	Revolt	26"	32	3	260
Razor Street	Revolt	24"	36	3	232
Razor Street	Revolt	24"	32	3	234
Razor Street	Fortress/Raider	26"	36	3	260
Razor Street	Fortress/Raider	26"	32	3	262
Razor Street	Fortress/Raider	24"	36	3	234
Razor Street	Fortress/Raider	24"	32	3	236
Razor Street	Fortress/Raider	20"	36	3	184
Razor Street	Fortress/Raider	20"	32	3	186
Sector Front	Revolt	26"	36	3	258
Sector Front	Revolt	24"	36	3	234
Sector Front	Fortress/Raider	26"	36	3	260
Sector Front	Fortress/Raider	24"	36	3	234
Sector Front	Fortress/Raider	20"	36	3	186
B-Two	Revolt	26"	36	3	256
B-Two	Revolt	26"	32	3	260
B-Two	Revolt	24"	36	3	232
B-Two	Revolt	24"	32	3	234
B-Two	Fortress/Raider	26"	36	3	258
B-Two	Fortress/Raider	26"	32	3	262
B-Two	Fortress/Raider	24"	36	3	234
B-Two	Fortress/Raider	24"	32	3	236
B-Two	Fortress/Raider	20"	36	3	184
B-Two	Fortress/Raider	20"	32	3	186

HUB MODEL	PITCH CIRCLE DIAMETER L (PCD LEFT)	PITCH CIRCLE DIAMETER R (PCD RIGHT)	FLANGE DISTANCE L (LEFT)	FLANGE DISTANCE R (RIGHT)	SPOKE HOLES DIAMETER
Revolt Pro Cassette 150x12mm	58	58	42	26.5	2.5
Revolt Pro Cassette 135x10mm; 135/142x12mm	58	58	34.5	19	2.5
Revolt Pro Singlespeed	58	58	34	38	2.5
Revolt Singlespeed	58	58	34	36	2.5
K-Drive	58	58	36	36	2.5
Quantic	58	49	42.4	28.4	2.5
Vee-One	58	49	34.5	20.9	2.5
Vee-Oh	58	49	34.5	20.9	2.5
X-Drive	49	49	34.4	34.4	2.5
Lite-Force	58	45	22.5	34.5	2.5
Dee-Force	58	58	22.5	34.5	2.5
B-15	45	45	34.5	34.5	2.5
X-15	58	45	22	36.4	2.5
Vee-Two	58	45	22	36.4	2.5
Razor/Razor v.2	45	58	27	26	2.5
Sector/Sector RHD/Sector LHD	45	58	29	29	2.5
B-One	45	45	28.5	28.5	2.5
Razor Park	34	34	39.5	39.5	2.5
Razor Street	38	38	36.5	36.5	2.5
Sector Front	34	34	39.5	39.5	2.5
B-Two	38	38	31.2	31.2	2.5

All dimensions in mm.
Please notice that some spokes calculators accept only values rounded to the full millimetre.

Frames	Wish shock bolts	10-12 Nm
	Wish main pivot axle over BB	10-12 Nm
	Wish main pivot axle TT/link	10-12 Nm
	Wish pivot axles SS/dropout	10-12 Nm
	Shine shock bolts (5mm Allen key)	10-12 Nm
	Shine BB/swing arm clamp bolts (4mm Allen key)	6-8 Nm
	Gyro tabs	4 Nm
	Deraillleur hanger	10 Nm
	Integrated seat post clamp	6 Nm
Fork	Cap	10 Nm
Cranks	Thorn/Flare assembly tool	50 Nm
	Thorn/Flare crank bolts	15 Nm
	Keipo/Chukka Two crank bolts	10 Nm
	Keipo/Chukka Two tightening bolts M6x18	12 Nm
	Sprocket bolts	20 Nm
BBs	Euro BB cups	40 Nm
Hubs	Vee-One/Vee-Two female bolts M6	10 Nm
	Sector/Sector Front/Vee-Oh tightening nuts	20 Nm
	Revolt Pro/Revolt/Razor/Razor Street 3/8" female bolts	25 Nm
	Razor Park M8 female bolts	18 Nm
	Rotor assembling	5 Nm
Stems	Rage/Micron/Funky/Fury bolts (all bolts)	8 Nm
	Reign/Reflect frontplate bolts	12 Nm
	Reign/Reflect steerer bolts	10 Nm
Pedals	Assembling in cranks	35 Nm
	Pins	5 Nm
Headsets	Top cap	8 Nm
Chain guides	Assembling cages to backplate	9 Nm
Grips	Barend/Lock ring	3 Nm
Saddles	Pivotal bolt	18 Nm

HEADSETS	BEARINGS SIZES	
	Upper	Bottom
Flash	41x30.15x7mm, 45x45°	41.8x30.5x8mm, 45x45°
Blaze	41x30.15x7mm, 45x45°	52x40x8mm, 45x45°
Dive	41x30.15x7mm, 45x45°	41.8x30.5x8mm, 45x45°
Spin	41x30.15x7mm, 45x45°	52x40x8mm, 45x45°
Astro	41x30.15x7mm, 45x45°	52x40x8mm, 45x45°
Exile	52x40x8mm, 45x45°	52x40x8mm, 45x45°
Charge	41x30.15x7mm, 45x45°	41.8x30.5x8mm, 45x45°
Prime	41.8x30.5x8mm, 45x45°	41.8x30.5x8mm, 45x45°
Moloko	41x30.15x7mm, 45x45°	41x30.15x7mm, 45x45°

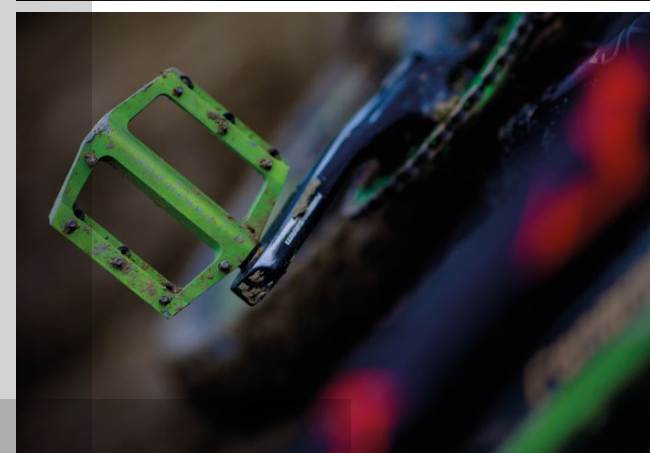
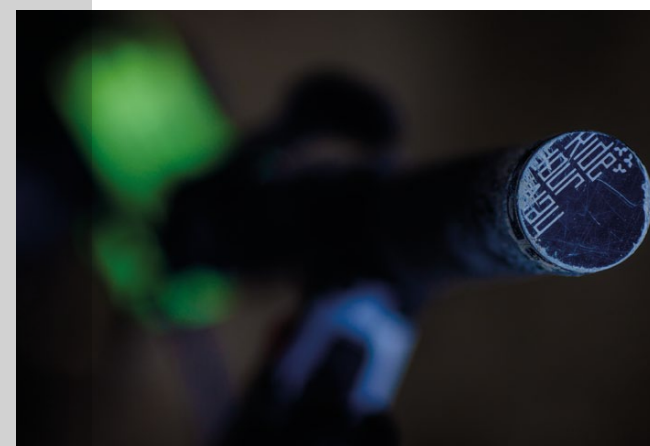

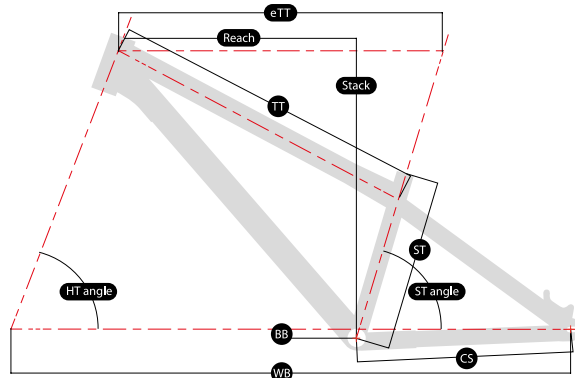
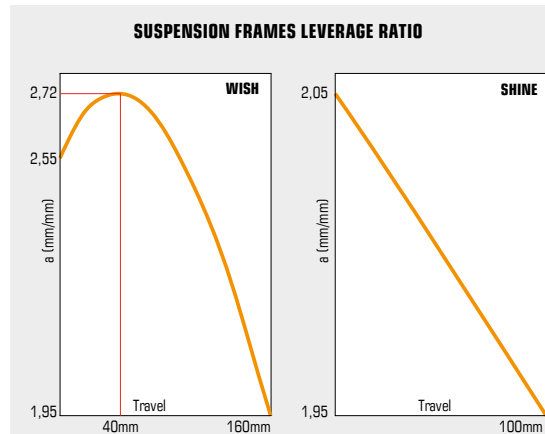

COMPLETE BIKES SPECS

Model	Wish Pro	Wish	Hornet	Shine	Two6Player Pro	Two6Player	Two4Player	Quinnie	Quantum
FRAME	alu 7005, 160mm travel	alu 7005, 160mm travel	alu 7005	alu 7005, 100mm travel	alu 7005	alu 6061	alu 6061	100% Cr-Mo 4130	DT/TT/CS/SS/dropout, Cr-Mo 4130*
FORK	RS Lyrik Solo Air R 160mm travel, 20mm axle	RST Storm Super tapered 160mm travel, 20mm axle	RST Storm Super TA 140mm travel, 20mm axle	Suntour DURO-DJ RC AIR 100mm travel, 20mm axle	Suntour DURO-DJ RC AIR 100mm travel, 20mm axle	Suntour Duro DJ D, 100mm travel, 3/8" axle	Suntour Duro DJ D, 100mm travel, 3/8" axle	Suntour DURO-DJ RC AIR 100mm travel, 20mm axle	rigid fork Cr-Mo 4130 steerer tube, offset 30mm
SHOCK	Rock Shox Monarch R 216x63mm	X-Fusion Vector R 216x63mm	-	Rock Shox Monarch R 190x51mm	-	-	-	-	-
BARS	Nitro, alu 7075 31.8mm/780mm	Fire, alu 6061 31.8mm/700mm	Fire, alu 6061 31.8mm/700mm	Ice, alu 6061 25.4mm/700mm	Ice, alu 6061 25.4mm/700mm	Ice, alu 6061 25.4mm/700mm	Ice, alu 6061 25.4mm/700mm	Ice, alu 6061 25.4mm/700mm	Ice, alu 6061 25.4mm/700mm
GRIPS	Icon	Icon	Icon	Icon	Icon	Shamann	Shamann	Shamann	Shamann
STEM	Fury OEM 2013, alu 6061 31.8mm/45mm	Fury 2012, alu 6061 31.8mm/40mm*	Fury 2012, alu 6061 31.8mm/40mm	Fury OEM 2013, alu 6061 25.4mm/35mm	Fury OEM 2013, alu 6061 25.4mm/35mm	Fury OEM 2013, alu 6061 25.4mm/35mm	Fury OEM 2013, alu 6061 25.4mm/35mm	Fury OEM 2013, alu 6061 25.4mm/35mm	Fury OEM 2013, alu 6061 25.4mm/35mm
HEADSET	Blaze OEM, tapered sealed bearings	Blaze OEM, tapered sealed bearings	1.1/8" semi-integrated sealed bearings	Flash OEM, tapered sealed bearings	Flash OEM, tapered sealed bearings	solid steel cups strong loose ball bearings	solid steel cups strong loose ball bearings	Neco, integrated 45°/45° sealed bearings	Neco, integrated 45°/45° sealed bearings
CRANKS	Truvativ Hussefelt 170mm crankarms	Truvativ Ruktion 170mm crankarms	Truvativ Ruktion 175mm crankarms	Truvativ Ruktion 170mm crankarms	Samox, 3-pcs tubular heat-treated Cr-Mo 4130 175mm crankarms	Chukka OEM, 3-pcs tubular heat-treated Cr-Mo 4130 175mm crankarms	Chukka OEM, 3-pcs tubular heat-treated Cr-Mo 4130 165mm crankarms	3-pcs tubular heat-treated 175mm crankarms	3-pcs tubular heat-treated 175mm crankarms
BB	Truvativ How XR73 BB	Truvativ How XR73 BB	-	Truvativ How XR73 BB	Euro 19mm, sealed bearings	Euro 19mm, sealed bearings	Euro 19mm, sealed bearings	Spanish 19mm, sealed bearings	Spanish 19mm, sealed bearings
CHAINRING	Totem 36T, alu 7075	36T, steel	36T, steel	32T, steel, with bushguard	Zulu 25T, alu 7075	32T, steel	32T, steel	Zulu 25T, alu 7075	32T, steel
CHAIN GUIDE	Blade ISCG-05	Blade ISCG-05	Blade ISCG-03	-	-	-	-	-	-
CHAIN	Shimano CN-HG53	KMC-X8	Accent AC-881 Pro	Core 3/32"	Core 1/8"	Core 1/8"	Core 1/8"	Core 1/8"	Core 1/8"
PEDALS	Stream Pro	Stream, replaceable pins	Stream, replaceable pins	Stream Pro	Stream Pro	Stream OEM, molded pins	Stream OEM, molded pins	Stream, replaceable pins	Stream OEM, molded pins
REAR DERAILLEUR	SRAM X-7	SRAM X-5	Shimano Sora-2300	-	-	-	-	-	-
SHIFTER	SRAM X-5, 9-speed	SRAM X-4, 8-speed	Shimano SL-M410, 8-speed	-	-	-	-	-	-
CASSETTE	SRAM PG-950, 11-28T	SRAM PG-830, 11-32T	Shimano CS-HG50-8, 12-25T	-	-	-	-	-	-
REAR HUB	Vee-Oh OEM, 36H sealed bearings	Vee-Oh OEM, 36H sealed bearings	X-Force OEM, 32H sealed bearings	Revolt SS OEM, 36H sealed bearings, 13T driver	Revolt SS OEM, 36H sealed bearings, 10T driver	male singlespeed, 36H sealed bearings, 14T freewheel	male singlespeed, 36H sealed bearings, 14T freewheel	Revolt SS OEM, 36H sealed bearings, 10T driver	male singlespeed, 36H sealed bearings, 14T freewheel
FRONT HUB	Revolt 20 OEM, 36H sealed bearings	Dee-Force, 36H sealed bearings	Dee-Force, 32H sealed bearings	Revolt 20 OEM, 36H sealed bearings	Revolt 20 OEM, 36H sealed bearings	3/8" male axle, 36H sealed bearings	3/8" male axle, 36H loose ball bearings	Revolt 20 OEM, 36H sealed bearings	3/8" male axle, 36H loose ball bearings
SPOKES	steel, brass nipples	steel, brass nipples	steel, brass nipples	steel, brass nipples	steel, brass nipples	steel, brass nipples	steel, brass nipples	steel, brass nipples	steel, brass nipples
RIMS	Raider 36H, double wall	Raider 36H, double wall	Raider 32H, double wall	Raider 36H, double wall	Raider 36H, double wall	Raider 36H, double wall	Raider 36H, double wall	Raider 36H, double wall	Shining 36H, double wall
TIRES	Kenda Nevegal 2.35"	Kenda Nevegal 2.35"	Kenda Kinetics 2.35"	Kenda SBE 2.1"	Kenda SBE 1.95"	Kenda K-Rad 2.3"	Kenda K-Rad 2.3"	Kenda SBE 1.95"	"Kenda K-Rad 2.3"
SEAT	Ivy, Pivotal	Ivy, Pivotal	Lite, Pivotal	Ivy, Pivotal	Lite Combo	Lite Combo	Lite Combo	Lite Combo	Lite Combo
SEAT POST	Fusion L, 31.6x300mm	Fusion L, 31.6x300mm	Fusion L, 31.6x300mm	Fusion, 27.2x200mm	-	-	-	-	-
SEAT CLAMP	34.9mm, alu 6061	34.9mm, alu 6061	34.9mm, alu 6061	31.8mm, alu 6061	31.8mm, alu 6061	31.8mm, alu 6061	31.8mm, alu 6061	integrated	integrated
BRAKE/LEVER	Avid Elixir 5	Promax DSK-907	Promax DSK-907	Avid Elixir 1	Avid Elixir 1	Promax DSK-320	Promax DSK-320	Avid Elixir 1	Alhonga V-Brake
WEIGHT	203mm rotor, front/rear 15.5kg	203mm rotor, front/rear 17.5kg	180mm rotor, front/rear 15.1kg	160mm rotor, front/rear 13.5kg	160mm rotor, rear 11.95kg	160mm rotor, rear 13.5kg	160mm rotor, rear 13.2kg	160mm rotor, rear 12.2kg	160mm rotor, rear 13.2kg

FRAMES GEOMETRY

MODEL	Wish		Shine		Cody		Quinnie		Ghetto		Freaky		Two6Player S size		Two6Player L size		Two4Player		Phantom		Hornet 14"		Hornet 16"		Hornet 18"	
	160mm (545mm)	180mm (565mm)	100mm (491mm)	140mm (531mm)	80mm (471mm)	100mm (491mm)	80mm (471mm)	100mm (491mm)	rigid fork (430mm)	80mm (471mm)	rigid fork (430mm)	100mm (491mm)	130mm (521mm)	100mm (491mm)	130mm (521mm)	80mm (471mm)	100mm (491mm)	80mm (471mm)	100mm (491mm)	130mm (521mm)	100mm (491mm)	150mm (541mm)	100mm (491mm)	150mm (541mm)	100mm (491mm)	150mm (541mm)
Top tube length (mm)	559	559	554	554	573	573	574	574	546	546	555	545	545	574	574	546	546	580	580	580	570	570	575	575	604	604
Effective top tube length (mm)	556	559	553	564	-	-	-	-	-	-	-	-	-	-	-	-	-	606	609	612	589	601	600	608	633	643
Chain stay length (mm)	425	425	403	403	380	380	383	383	360	360	365	385	385	385	385	370	370	400	400	400	420	420	420	420	420	420
Seat tube height (mm)	343	343	305	305	300	300	300	300	270	270	255	310	310	310	310	300	300	340	340	340	356	356	406	406	460	460
Reach (mm)	403	392	410	387	414	402	414	402	410	390	418	382	367	412	397	402	394	422	412	392	401	374	411	380	446	418
Stack (mm)	576	583	550	565	534	543	534	543	491	607	510	566	576	566	576	530	539	552	559	572	578	600	577	601	580	600
Wheel base (mm)	1128	1135	1072	1081	1037	1044	1043	1050	960	988	966	1029	1040	1059	1070	1010	1016	1069	1078	1089	1066	1086	1078	1096	1118	1131
BB height (mm)	+12	+25	+3	+16	-5	0	-5	0	11.5"	11.5"	+5	-18	-8	-18	-8	-3	+3	-20	-13	0	-26	-8	-26	-8	-26	-8
Head tube angle	66.5°	65.5°	69.5°	67.5°	69.5°	68.5°	69.5°	68.5°	71.5°	70°	72.5°	68°	67°	68°	67°	70°	69°	69°	67°	66°	69.5°	67.5°	69.5°	67.5°	69.5°	67.5°
Seat tube angle	75°	74°	-	-	-	-	-	-	-	-	-	-	-	-	-	-	-	-	-	-	71.5°	69.5°	71.5°	69.5°	71.5°	69.5°



Nico Scholze from Stuttgart, Germany is one of the most promising young MTB riders in Europe. So far his best results were top 10 in Scott On Air in Willingen and SKS Slopestyle Masters in Winterberg but with doubleflip or cordova backflip in his bag of tricks his prospects are a way better !! We proudly support him now with Two6Player and Wish Pro bikes.

NICO SCHOLZE

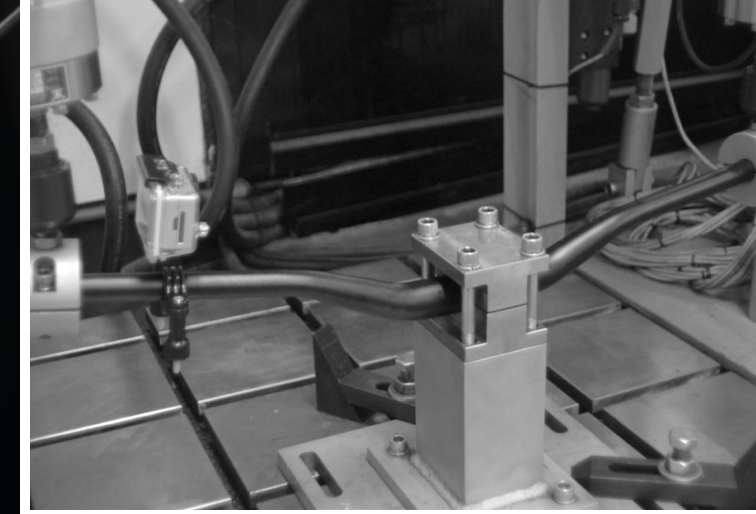

**INNOVATIVE
ECONOMY**
NATIONAL COHESION STRATEGY

EUROPEAN UNION
EUROPEAN REGIONAL
DEVELOPMENT FUND



European Funds – for the development of innovative economy
We invest in your future

DARTMOOR-BIKES.COM



facebook.com/dartbikes